

havasis

ÇÖZÜMÜN
İLK ADI



Kurumsal & Ürünler
havasis.com.tr



Sipariş & Danışma Hattı
0549 449 3535

Teklif & Ürün Bilgi
hemendene@havasis.com.tr

Kalibrasyon & Bakım Onarım Merkezi
servisdestek@kalibo.com.tr

AcraDyne®
A Division of AIMCO
Katalog

**HIGH
CAPABILITY
TOOLING**

TABLE OF CONTENTS

CONTROLLED TOOLS

AcraDyne®

GEN IV ACE Controller Platform	4
Controller Software	11
GEN IV Smart Arm System with Process Visualization	12
1000 Series Nutrunners	14
2000 Series Nutrunners	17
2000 Series AcraDrive Discontinuous Drive Nutrunners	21
3000 Series Nutrunners	23
5000 Series Nutrunners	25
AcraDyne Specialty Gearheads	28
Riv-Nut Tools	29
HT Series DC Tools	30
HT Series DC Angle Tools	32
HT Series DC Dual-Lever Tools	35
HTXD Extreme Duty High-Torque Tools	37
Gen IV Field Controller	40
HT Series Nose Extensions and Gearhead Tools	41
HT Series DC Tool Accessories	42
DC Tool / Spindle Selection Guide	43
Cables and Accessories	45
Cordless AB Series	48
Cordless ABP Ultra Torque Series	51
Multiple Nutrunning Systems	53
AIMCO Tool Specials	54

POWER TOOLS

AcraDyne HT Series Pneumatic Tools	55
Pneumatic Tool Accessories	57

TOOL SUPPORT SYSTEMS

Ergo Arms®	58
Carbon Torque Arms	60
Carbon Torque Tubes	63
GCI Torque Reaction Arms	65
3arm Zero Gravity Arms	68
Support System Tool-Mounting Options	73
Air Preparation Units	74

Index	75
-----------------	----



* **E** logo indicates where ERGO-DRIVE sockets/extensions benefit tool operation.

ERGO-DRIVE sockets are uniquely designed for repeatable, accurate rundowns. They also ensure excellent product quality, longer tool life, and better ergonomics for the tool user. Look for the ERGO-DRIVE **E** logo in this catalog to see where ERGO-DRIVE sockets/extensions benefit tool operation, operator, and rundown.

AcraDyne's Gen IV ACE Controller platform is a single platform that commands all transducerized tools in the AIMCO portfolio

AIR | CORDLESS | ELECTRIC



The same, simple programming for all tool types, including:

AcraDyne

- DC Tools
- Cordless Battery Tools

Uryu

- Air Powered Tools
- Electric Tools
- Pulse Tools

No additional controller training needed for different platforms (tool type specific knowledge is required).

One common communication for global data collection, line controls, and Field Bus platforms.



AcraDyne Gen IV ACE Controller Platform

The AcraDyne Gen IV ACE controller platform is the culmination of more than 40 years of serving our industrial fastening customers with 15 years of designing and manufacturing DC tools that are Designed and Assembled in the USA. It is filled with countless advanced capabilities and features. The Gen IV ACE Controller is the core of the modular AcraDyne DC system. One controller will command any tool in the AcraDyne line from 1 Nm to 17,000 Nm, all with one cable.



Four Digit LED Torque Display

Large numbers can be seen from a distance.

Secondary Display

Allows user to easily set and toggle through information:

- Angle
- Engineering Units
- Bolt Count
- Job/Job Sequence

Parameter Set Display

Displays current parameter set and enables user to quickly change by scrolling up or down.

7" Touch-Screen Display

- Runs the same software on PC for ease of use
- Real-Time Graphing
- Selectable Run Screens

FEATURES AND BENEFITS

- Web browser based programming. Receive data on your PC, tablet, smartphone, or any other web-capable device. You can use more than one device at a time: Be in program mode on one device while reviewing real-time curves on another, while watching tool diagnostics on a third
- Multiple fastening strategies - Program up to 256 parameters with as many as 20 steps
- Jobs capability - 99. Event log - 5,000
- Backup & restore through USB or Ethernet
- Assignable I/O (8 X 8)
- Rundown storage - 1,000,000
- Real-time curve viewing. Curve storage - 20,000

NETWORKING CAPABILITIES

- Ethernet Protocols supported: Open Protocol, ToolsNet, Ethernet/IP, Modbus TCP, PFCS, XML, FTP Client
-  Anybus® Field Bus connectivity: Profibus, Profinet, DeviceNet, CC-Link, CC-Link IE Field
- Data collection
- Serial protocols and string output
- Bar code scanning & printing
- Multi-spindle synchronization

AcraDyne Gen IV ACE Controller Platform

System Port

- Uses standard USB Type-B cable
- Easily connect to any computer to run software, program your controller, and download data and curves

Tool Connector

- Tool connector varies by tool type

Dual Ethernet Ports

- Enables two networks simultaneously for separate line control and data collection
- Supports any industry standard protocol
- Remote system monitoring, programming, and data download

USB Ports (4)

- Backup and Restore
- Update Software
- Download Data and Curves
- Expandable USB Peripherals

Illuminated On/Off Switch

Power Connector (110V / 220V)

Anybus® Field Bus Options:

- Profibus, Profinet, DeviceNET, CC-Link, CC-Link IE Field

Serial Port

- Data String Output
- Serial Protocols
- Bar Code Scanners
- Printers

24V I/O (Assignable)

- 8 In/8 Out

Mounting Bracket

with Wire and Cable Routing Channels

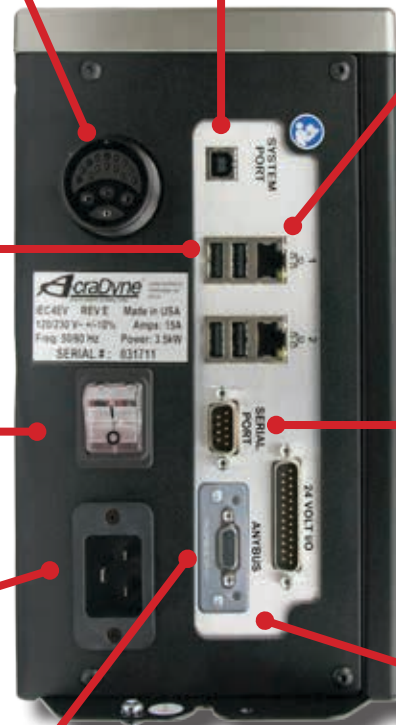

AcraDyne Gen IV ACE Controller Platform

The Gen IV ACE Controller Platform provides ultimate FLEXIBILITY and FREEDOM to command tools for every application. One common communication for your global data collection, line controls, and Field Bus platforms.

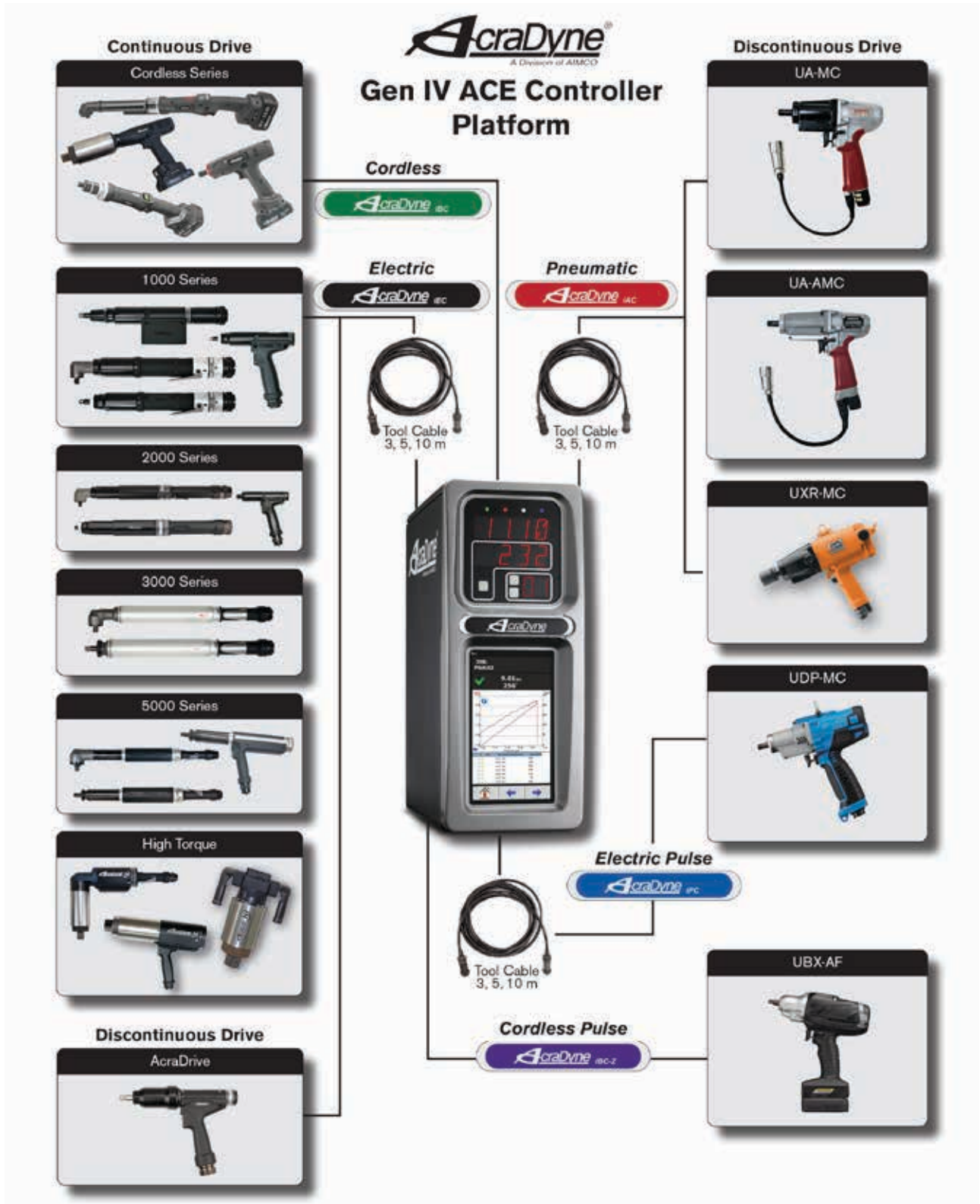

AcraDyne Gen IV ACE Controller Platform



GEN IV ACE iEC Controller for all AcraDyne DC Tools



U.S. Patent D968491

Model*	System Port & Removable Memory	Lights (L) LED Display (D) Graph (G)	24V I/O Assignable 8 X 8"	Serial Port with Protocols	Backup & Restore (USB)	Ethernet** Two Ports
Bottom Exit Cable						
iEC4EGV(P)(N)(D)(C)(M)	X	L/D/G	X	X	X	X
Top Exit Cable						
iEC4EGV(-T)(P-T)(N-T)(D-T)(C-T)(M-T)	X	L/D/G	X	X	X	X

* Field bus options: P = Profibus N = Profinet D = DeviceNet C = CC Link M = CC-Link IE Field Other Field bus options available upon request.
 ** Ethernet channel supports Open Protocol, ToolsNet, EtherNet/IP, Modbus TCP, PFCS, XML, and FTP Client.



GEN IV ACE iAC Controller for Transducerized Uryu Air Tools



Model*	System Port & Removable Memory	Lights (L) LED Display (D) Graph (G)	24V I/O Assignable 8 X 8"	Serial Port With Protocols	Backup & Restore (USB)	Solenoid Shut Off On Board	Programmable Regulator On Board	Ethernet** Two Ports
Bottom Exit Cable								
iAC4EGV(P)(N)(D)(C)(M)	X	L/D/G	X	X	X			X
iAC4ESRGV(P)(N)(D)(C)	X	L/D/G	X	X	X	X	X	X
Top Exit Cable								
iAC4EV(P-T)	X	L/D	X	X	X			X
iAC4EGV(-T)(P-T)(N-T)(D-T)(C-T)	X	L/D/G	X	X	X			X
iAC4ESRGV(-T)(P-T)(N-T)(D-T)(C-T)	X	L/D/G	X	X	X	X	X	X

* Field bus options: P = Profibus N = Profinet D = DeviceNet C = CC Link M = CC-Link IE Field Other Field bus options available upon request.
 ** Ethernet channel supports Open Protocol, ToolsNet, EtherNet/IP, Modbus TCP, PFCS, XML, and FTP Client.

AcraDyne Gen IV ACE Controller Platform



GEN IV ACE iPC Controller for Uryu UDP Transducerized DC Pulse Tools



Model*	System Port & Removable Memory	Lights (L) LED Display (D) Graph (G)	24V I/O Assignable 8 X 8"	Serial Port with Protocols	Backup & Restore (USB)	Ethernet** Two Ports
Bottom Exit Cable						
<u>110V Operation</u> iPC4EGV(P1)(N1)(D1)(C1)(M1)	X	L/D/G	X	X	X	X
<u>220V Operation</u> iPC4EGV(P2)(N2)(D2)(C2)	X	L/D/G	X	X	X	X
Top Exit Cable						
<u>110V Operation</u> iPC4EGV(1-T)(P1-T)(N1-T)(D1-T)(C1-T)(M1-T)	X	L/D/G	X	X	X	X
<u>220V Operation</u> iPC4EGV(2-T)(P2-T)(N2-T)(D2-T)(C2-T)	X	L/D/G	X	X	X	X

* Field bus options: P = Profibus N = Profinet D = DeviceNet C = CC Link M = CC-Link IE Field Other Field bus options available upon request.
** Ethernet channel supports Open Protocol, ToolsNet, EtherNet/IP, Modbus TCP, PFCS, XML, and FTP Client.



GEN IV ACE iBC Controller for all AcraDyne Transducerized Battery Tools



Model*	System Port & Removable Memory	Lights (L) LED Display (D) Graph (G)	24V I/O Assignable 8 X 8"	Serial Port with Protocols	Backup & Restore (USB)	Ethernet** Two Ports
Connects through External WiFi Access Point (User Supplied)						
iBC4E(N)	X	L/D		X	X	X
iBC4EGV(P)(N)(D)(C)	X	L/D	X	X	X	X

* Field bus options: P = Profibus N = Profinet D = DeviceNet C = CC Link M = CC-Link IE Field Other Field bus options available upon request.
** Ethernet channel supports Open Protocol, ToolsNet, EtherNet/IP, Modbus TCP, PFCS, XML, and FTP Client.



GEN IV ACE iBC-Z Controller for Uryu UBX-AF Transducerized Battery Oil Pulse Tools



Model*	System Port & Removable Memory	Lights (L) LED Display (D) Graph (G)	24V I/O Assignable 8 X 8"	Serial Port With Protocols	Backup & Restore (USB)	Ethernet** Two Ports
Connectivity through embedded Zigbee access point						
iBC4EGV(P-Z)(N-Z)(D-Z)(C-Z)(M-Z)	X	L/D/G	X	X	X	X

* Field bus options: P = Profibus N = Profinet D = DeviceNet C = CC Link M = CC-Link IE Field Other Field bus options available upon request.
** Ethernet channel supports Open Protocol, ToolsNet, EtherNet/IP, Modbus TCP, PFCS, XML, and FTP Client.

AcraDyne Gen IV ACE Controller Platform

NETWORK CONNECTIVITY



POKA-YOKE ERROR PROOFING

AcraDyne's Gen IV ACE Platform supports any third-party accessory to poka-yoke your process.

FEATURES AND BENEFITS

- 24V I/O inputs support the outputs of the receiver units
- Connect click wrenches, crimpers, or any poka-yoked device to your network data collection and line controls with all of the Ethernet protocols and Field Buses offered in the ACE Platform



AcraDyne Controller Software

SOFTWARE

AcraDyne's software package is on-board every AcraDyne controller and is provided FREE of charge. This comprehensive, user-friendly program allows programming, analysis, and diagnostics.

The software is based on a standard web browser, allowing you to connect the AcraDyne controller with any computer, tablet, or smart device. Connect through Ethernet, USB, or wirelessly via a network connected to both devices.

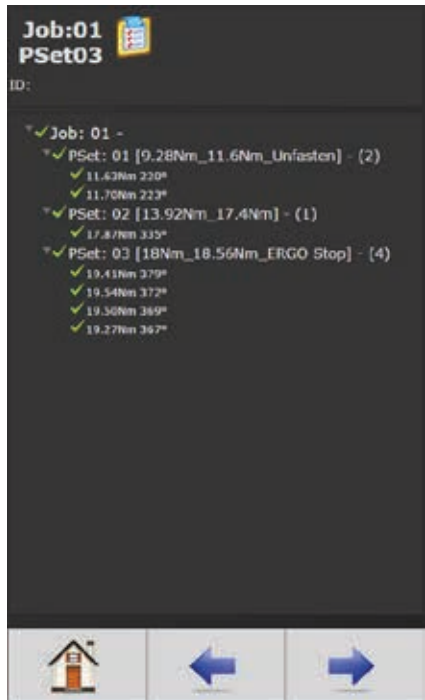

Adding and editing Parameter Sets (256) and Jobs (99) is easy and intuitive in the parameter set up function.

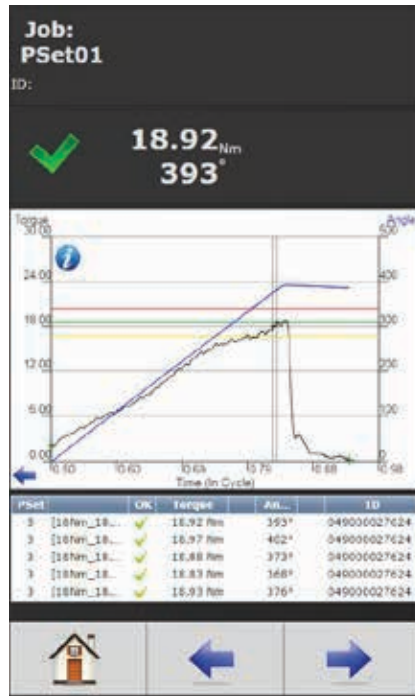

View curve results in real time or view stored results. As many as 20,000 curve results can be stored in memory.

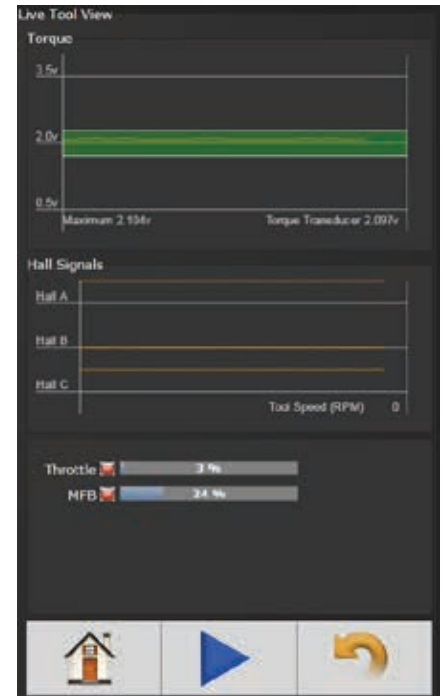

Tool programming and diagnostics for repair, calibration and advanced troubleshooting.



Choose from several run screens that display easy to view, large screen indicators.

Gen IV Smart Arm System With Process Visualization

Gen IV Controller with On-Board Smart Arm Capability and Process Visualization

AcraDyne Gen IV Controller's smart arm capability provides an advanced error-proofing solution to ensure the quality of your fastening operation. The process requires no external PC or software – the capability is on-board every Gen IV controller.

FEATURES AND BENEFITS

- Easy-to-follow visual guidance on the Gen IV controller graphical screen
- Easy setup – programming takes only minutes
- Once fastener locations are programmed into the Gen IV controller, the system can perform specific actions on specific fasteners
- No external PC or third-party software needed. Control the process using AcraDyne's Gen IV Controller and its integrated software, which is provided free of charge
- Low-cost solution vs. competitive offerings that require third-party PC-based control
- Modular – can be added at any time to an existing AcraDyne system using the Gen IV controller
- No guesswork! Powerful Gen IV data collection enables diagnostics and analysis
- Works with both continuous and discontinuous drive tools



The Gen IV controller provides easy-to-follow visual guidance directly on the graphical screen.

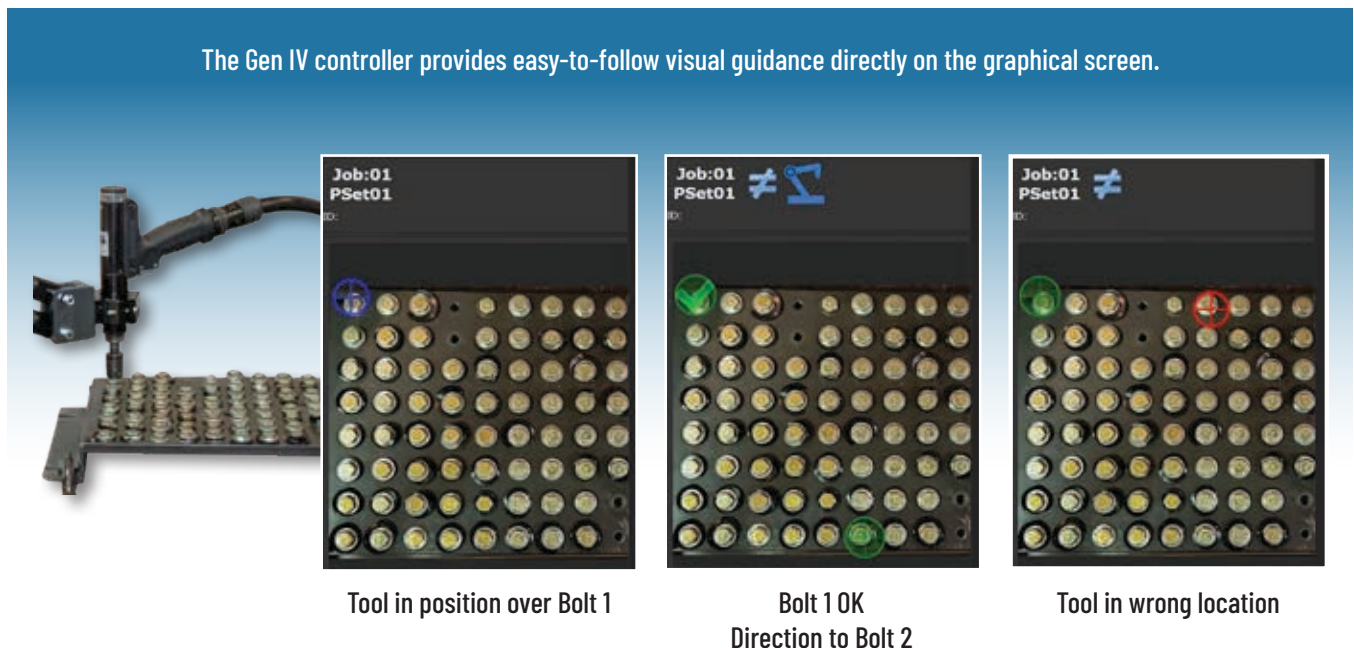

Gen IV Smart Arm System With Process Visualization



Gen IV Smart Arm System with Process Visualization

Smart Arm Accessory:

- Requires no external PC or third-party software for operation
- Gen IV Controller Software integrates with plant manufacturing execution software or allows custom programming

Smart Arm guides operator in the specified torque pattern and counts fasteners required for correct assembly.

Encoders located at each joint of the arm.

Gen IV Controller captures fastening-process data:

- Data captured and reported in real time with torque and graphing capabilities
- Curve results presented in real time or from stored results
- 20,000 curve results can be stored in memory
- Monitor, control, and report torque, angle, engineering units, fastener count, job/job sequence
- Multiple fastening strategies: 256 parameter sets with 20 stages
- Jobs capabilities - 99

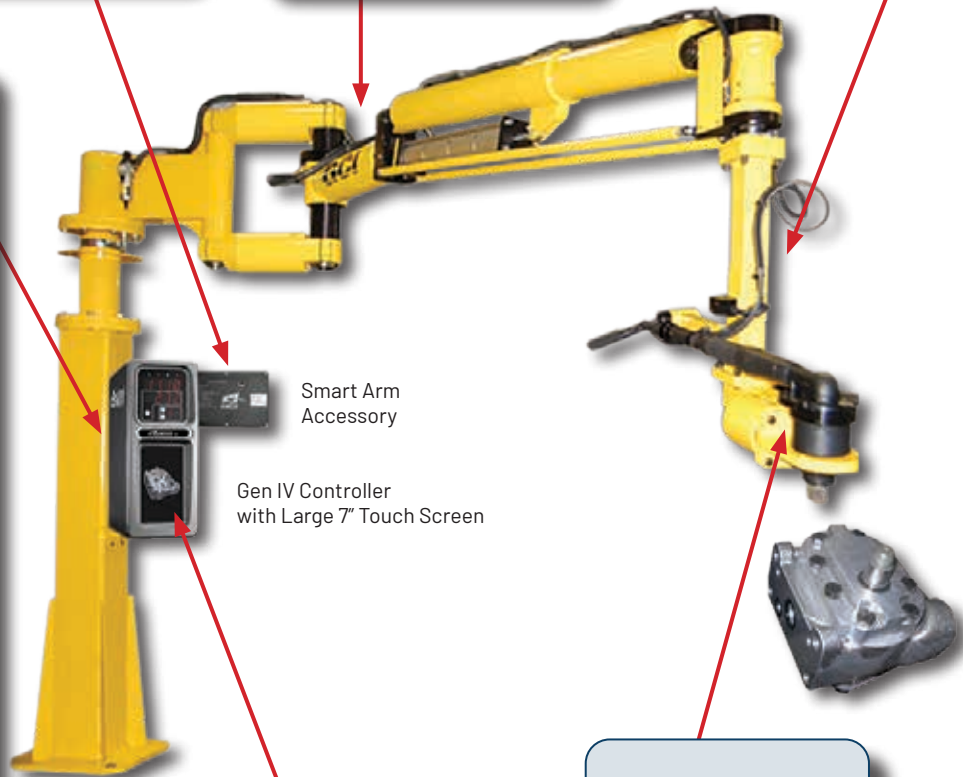

Smart Arm Accessory

Gen IV Controller with Large 7" Touch Screen

Custom image of run screen with preprogrammed fastener locations/specifications. Updates in real time.

Tool operates only when it is at the correct specified fastener location.

1000 SERIES

1 – 22 Nm

- Superior size, speed, and duty cycle compared to competitors' tools
- Durable Nylon motor and handle housing
- Onboard lights and audible signal for operator feedback



1000 Series Pistol Tools

- Bottom, top, rear exit and push-to-start models available
- Standard Square Drive or extended Ergo Drive output available on all models
- 1/4" Quick Change output available on 3 – 14 Nm models
- Programmable Multi-Function Button: One single button facilitates several distinctly different tasks

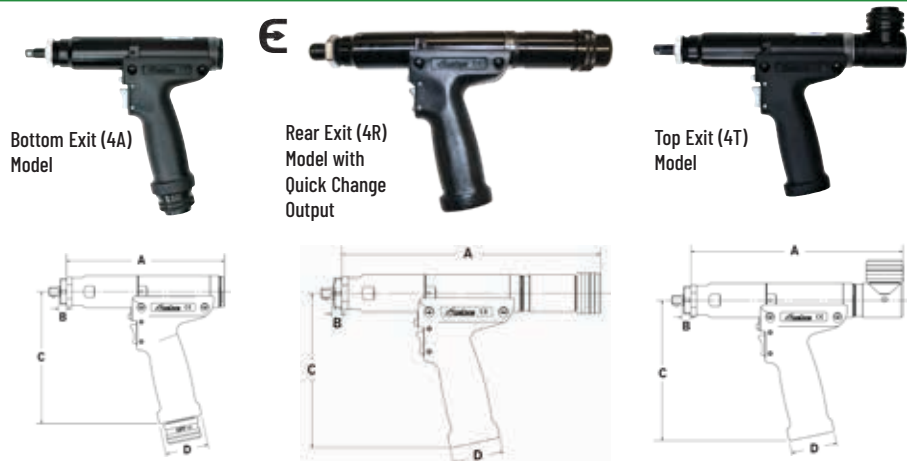

1000 Series Pistol Tools

Model	Max Torque		Torque Range		Free Speed RPM	Weight (-) Socket		Output Drive SQ DR	A		B		C		D	
	NM	FT-LB	NM	FT-LB		LB	KG		IN	MM	IN	MM	IN	MM	IN	MM
Pistol 4A Models = Bottom Exit 4R Models = Rear Exit 4T Models = Top Exit (V) = Extended Ergo-Drive Output (Q) = 1/4" Quick Change Output																
AEP4(A)(R)(T)12003B(V)(Q)	3	2.2	0.8 - 3	0.6 - 2.2	2,625	2.2	1.00	3/8"	A = 6.5 R = 9.3 T = 8.3	165.1 236 210.9	0.38	9.6	6.01	152.6	1.96	49.7
AEP4(A)(R)(T)12006B(V)(Q)	6	4.4	1.5 - 6	1.1 - 4.4	2,625	2.2	1.00	3/8"	A = 6.5 R = 9.3 T = 8.3	165.1 236 210.9	0.38	9.6	6.01	152.6	1.96	49.7
AEP4(A)(R)(T)12011B(V)(Q)	11	8.1	2.8 - 11	2 - 8.1	1,313	2.3	1.04	3/8"	A = 7.17 R = 10.34 T = 8.97	182.2 262.7 228	0.38	9.6	6.01	152.6	1.96	49.7
AEP4(A)(R)(T)12014B(V)(Q)	14	10	3.5 - 14	2.6 - 10	1,037	2.3	1.04	3/8"	A = 7.17 R = 10.34 T = 8.97	182.2 262.7 228	0.38	9.6	6.01	152.6	1.96	49.7
AEP4(A)(R)(T)12018BV	18	13	4.5 - 18	3.3 - 13	840	2.3	1.04	3/8"	A = 7.17 R = 10.34 T = 8.97	182.2 262.7 228	0.38	9.6	6.01	152.6	1.96	49.7
AEP4(A)(R)(T)12022BV	22	16	5.5 - 22	4.1 - 16	656	2.3	1.04	3/8"	A = 7.17 R = 10.34 T = 8.97	182.2 262.7 228	0.38	9.6	6.01	152.6	1.96	49.7
Pistol Push-to-Start																
AEP4T12003BL	3	2.2	0.8 - 3	0.6 - 2.2	2,625	2.2	1.00	3/8"	8.88	225.5	0.25	6.3	6.01	152.6	1.96	49.7
AEP4T12006BL	6	4.4	1.5 - 6	1.1 - 4.4	2,625	2.2	1.00	3/8"	8.88	225.5	0.25	6.3	6.01	152.6	1.96	49.7
AEP4T12011BL	11	8.1	2.8 - 11	2 - 8.1	1,313	2.3	1.04	3/8"	8.97	228	0.25	6.3	6.01	152.6	1.96	49.7
AEP4T12014BL	14	10	3.5 - 14	2.6 - 10	1,037	2.3	1.04	3/8"	8.97	228	0.25	6.3	6.01	152.6	1.96	49.7

* € logo indicates where ERGO-DRIVE sockets/extensions benefit tool operation.

1000 Series Angle Tools

- Compact, durable head houses a precision right-angle gearset that fits into the tightest spaces
- Integrated transducer for accurate delivery or monitoring of Torque and Angle
- Lightweight materials and uniform body diameter provide a comfortable grip
- Ergonomically placed start lever for ease of operation
- Available in regular or flush socket options

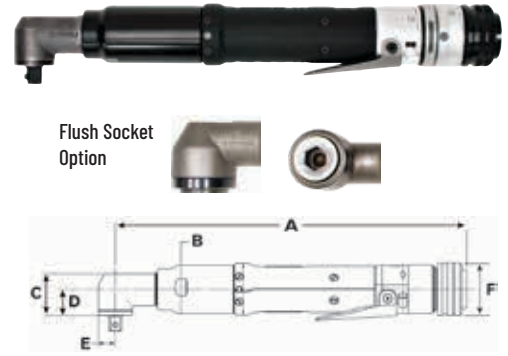

1000 Series Angle Tools

Model	Max Torque		Torque Range		Free Speed RPM	Weight (-)Socket		Output Drive SQ DR	A		B		C		D		E		F		
	NM	FT-LB	NM	FT-LB		LB	KG		IN	MM	IN	MM	IN	MM	IN	MM	IN	MM	IN	MM	
Angle Add "F" to Part Numbers for Flush Socket																					
AEN4C12004B	4	3	1-4	0.7-3	3,111	2.0	0.91	3/8"	11.04	280.4	1.47	37.3	1.29	32.8	0.82	20.9	.52	13.1	1.56	39.6	
AEN4C12009B	9	6.6	2.3-9	1.7-6.6	1,750	2.2	1.00	3/8"	11.01	279.6	1.47	37.3	1.29	32.8	0.82	20.9	.52	13.1	1.56	39.6	
AEN4C12014B	14	10	3.5-14	2.6-10	875	2.2	1.00	3/8"	11.65	295.9	1.47	37.3	1.29	32.8	0.82	20.9	.52	13.1	1.56	39.6	
AEN4C12018B	18	13	4.5-18	3.3-13	691	2.2	1.00	3/8"	11.65	295.9	1.47	37.3	1.29	32.8	0.82	20.9	.52	13.1	1.56	39.6	
AEN4C12022B	22	16	5.5-22	4.1-16	560	2.2	1.00	3/8"	11.65	295.9	1.47	37.3	1.29	32.8	0.82	20.9	.52	13.1	1.56	39.6	

1000 Series Inline Tools

- Square drive or Ergo drive available on all inline models
- Quick change output available on 3 - 14 Nm inline and push-to-start models
- User modifiable reaction bar included with in-line tools for use in handheld applications



1000 Series Inline Tools

Model	Max Torque		Torque Range		Free Speed RPM	Weight (-)Socket		Output Drive SQ DR	A		B		C		D		E	
	NM	FT-LB	NM	FT-LB		LB	KG		IN	MM	IN	MM	IN	MM	IN	MM	IN	MM
Inline V = Extended Ergo-Drive Output Q = 1/4" Quick Change Output																		
AES4A12003B(V)(Q)	3	2.2	0.8-3	0.6-2.2	2,625	2.0	0.91	3/8"	11	279.4	1.47	37.3	7.43	188.6	1.56	39.6	1.31	33.4
AES4A12006B(V)(Q)	6	4.4	1.5-6	1.1-4.4	2,625	2.0	0.91	3/8"	11	279.4	1.47	37.3	7.43	188.6	1.56	39.6	1.31	33.4
AES4A12011B(V)(Q)	11	8.1	2.8-11	2-8.1	1,313	2.2	1.00	3/8"	11	279.4	1.47	37.3	7.43	188.6	1.56	39.6	1.31	33.4
AES4A12014B(V)(Q)	14	10	3.5-14	2.6-10	1,037	2.2	1.00	3/8"	11	279.4	1.56	39.6	7.43	188.6	1.56	39.6	1.31	33.4
AES4A12018BV	18	13	4.5-18	3.3-13	840	2.2	1.00	3/8"	11	279.4	1.47	37.3	7.43	188.6	1.56	39.6	1.31	33.4
AES4A12022BV	22	16	5.5-22	4.1-16	656	2.2	1.00	3/8"	11	279.4	1.47	37.3	7.43	188.6	1.56	39.6	1.31	33.4
Inline Push-to-Start (Q) = 1/4" Quick Change Output																		
AEL4A12003B(Q)	3	2.2	0.8-3	0.6-2.2	2,625	2.0	0.91	3/8"	10.69	271.6	1.56	39.6	7.38	187.4	0.21	5.3	1.56	39.6
AEL4A12006B(Q)	6	4.4	1.5-6	1.1-4.4	2,625	2.0	0.91	3/8"	10.69	271.6	1.56	39.6	7.38	187.4	0.21	5.3	1.56	39.6
AEL4A12011B(Q)	11	8.1	2.8-11	2-8.1	1,313	2.2	1.00	3/8"	11.26	286.1	1.56	39.6	7.38	187.4	0.21	5.3	1.56	39.6
AEL4A12014B(Q)	14	10	3.5-14	2.6-10	1,037	2.2	1.00	3/8"	11.26	286.1	1.56	39.6	7.38	187.4	0.21	5.3	1.56	39.6
AEL4A12018B	18	13	4.5-18	3.3-13	840	2.2	1.00	3/8"	11.26	286.1	1.56	39.6	7.38	187.4	0.21	5.3	1.56	39.6
AEL4A12022B	22	16	5.5-22	4.1-16	656	2.2	1.00	3/8"	11.26	286.1	1.56	39.6	7.38	187.4	0.21	5.3	1.56	39.6

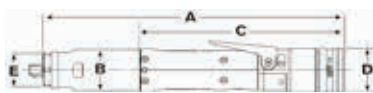

Inline Tool, 3 - 22 Nm

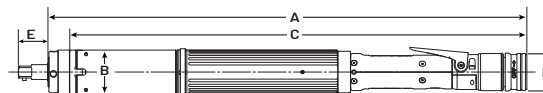

Inline Tool, 100 Nm



Push-to-Start Tool

* E logo indicates where ERGO-DRIVE sockets/extensions benefit tool operation.

1000 Series Tubenut Tools

- Durable tubenut head design
- Simple, one-touch back to open operation for maximum productivity
- Innovative Sensor Technology: Transducer senses resistance in the initial 90 degrees of rotation and returns to open upon resistance encountered

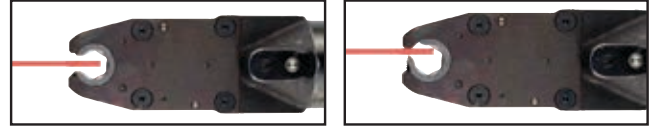
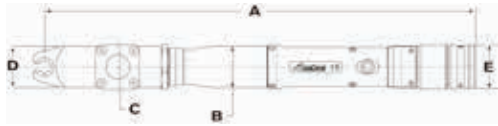

INNOVATIVE SAFETY SENSOR TECHNOLOGY: Tool returns to open upon resistance encountered in initial 90° of rotation.

1000 Series Tubenut Tools

1000 Series Tubenut	Max Torque		Torque Range		Free Speed RPM	Weight (-)Socket		Output Drive		A		B		C		D		E	
	NM	FT-LB	NM	FT-LB		LB	KG	IN	MM	IN	MM	IN	MM	IN	MM	IN	MM	IN	MM
Tubenut Wide variety of socket sizes available																			
AET4AA12018B	14	13	3.6 - 14	2.7 - 11	516	3.1	1.41	1/4 - 7/16	7 - 12	15.4	391.5	1.47	37.3	1.57	40	1.46	37	1.56	39.6
AET4AB12025B	20	18	5 - 20	3.7 - 15	387	3.1	1.41	3/8 - 5/8	10 - 17	15.9	404.9	1.47	37.3	1.57	40	1.56	39.5	1.56	39.6
AET4A12025B-KD	25	18	5 - 25	3.7 - 18	387	3.1	1.41	3/8 - 5/8	10 - 17	15.9	403.2	1.47	37.3	1.64	41.6	1.64	41.6	1.56	39.6
AET4A12030B-KD	30	22	6 - 30	4.4 - 22	285	3.1	1.41	3/8 - 5/8	10 - 17	15.9	403.2	1.47	37.3	1.64	41.6	1.64	41.6	1.56	39.6

1000 Series Fixtured Tools

- Rear & bottom exit available
- Standard Square Drive, Extended Ergo Drive, or 1/4" Quick Change outputs available in most models
- Integrated Sliding Spindles offered in varying lengths of travel to suit specific application needs



1000 Series Fixtured Tools

Model	Max Torque		Torque Range		Free Speed RPM	Weight (-)Socket		Output Drive SQ DR
	NM	FT-LB	NM	FT-LB		LB	KG	
Fixtured 4A models = 1/2" sliding spindle 4C Models = 1-3/4" Sliding Spindle 4X Models = Fixed 3/8" Sq. Dr. (B) = Bottom Exit Cable (Q) = 1/4" Quick Change Output								
AEF4(A)(C)(X)12003B(B)(Q)	3	2.2	0.8 - 3	0.6 - 2.2	2,625	2.0	0.91	3/8"
AEF4(A)(C)(X)12006B(B)(Q)	6	4.4	1.5 - 6	1.1 - 4.4	2,625	2.0	0.91	3/8"
AEF4(A)(C)(X)12011B(B)(Q)	11	8.1	2.8 - 11	2 - 8.1	1,313	2.2	1.00	3/8"
AEF4(A)(C)(X)12014B(B)(Q)	14	10	3.5 - 14	2.6 - 10	1,037	2.2	1.00	3/8"
AEF4(A)(C)(X)12018B(B)	18	13	4.5 - 18	3.3 - 13	840	2.2	1.00	3/8"
AEF4(A)(C)(X)12022B(B)	22	16	5.5 - 22	4.1 - 16	656	2.2	1.00	3/8"

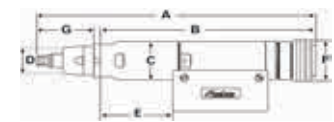

AEF4A 1/2" Sliding Spindle Model

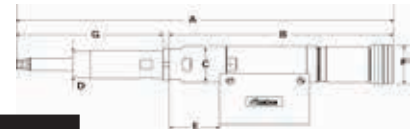

AEF4C 1-3/4" Sliding Spindle Model

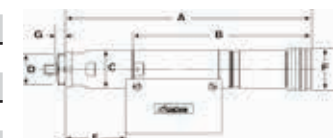

AEF4X Fixed 3/8" Sq. Dr. Model

1000 Series Fixtured Tool Dimensions

Fixtured	A		B		C		D		E		F		G	
	IN	MM	IN	MM	IN	MM	IN	MM	IN	MM	IN	MM	IN	MM
AEF4A12003B / AEF4A12006B	11.57	294	9.14	231.1	1.47	37.3	1.12	28.6	2.05	52.2	1.59	40.4	2.18	55.5
AEF4A12011B / AEF4A12014B / AEF4A12018B / AEF4A12022B	12.20	309.8	9.14	231.1	1.47	37.3	1.12	28.6	2.72	69.2	1.59	40.4	2.18	55.5
AEF4C12003B / AEF4C12006B	15.36	390.3	9.14	231.1	1.47	37.3	1.12	28.6	2.05	52.2	1.59	40.4	5.98	151.8
AEF4C12011B / AEF4C12014B / AEF4C12018B / AEF4C12022B	15.99	406.1	9.14	231.1	1.47	37.3	1.12	28.6	2.72	69.2	1.59	40.4	5.98	151.8
AEF4X12003B / AEF4X12006B	9.35	237.5	6.82	173.2	1.47	37.3	1.31	33.4	2.06	52.2	1.59	40.4	0.38	9.7
AEF4X12011B / AEF4X12014B / AEF4X12018B / AEF4X12022B	10.02	254.4	6.82	173.2	1.47	37.3	1.31	33.4	2.72	69.1	1.59	40.4	0.38	9.7

*E logo indicates where ERGO-DRIVE sockets/extensions benefit tool operation.

2000 SERIES

3 – 55 Nm

- Superior size, speed, and duty cycle compared to competitors' tools
- Durable Nylon motor and handle housing
- Aluminum motor and gear housing
- Onboard lights and audible signal for operator feedback



2000 Series Pistol Tools

- Bottom, top, rear exit and push-to-start model available
- Standard Square Drive or extended Ergo Drive output available on all models
- Programmable Multi-Function Button: One single button facilitates several distinctly different tasks



Bottom Exit (4A) Model

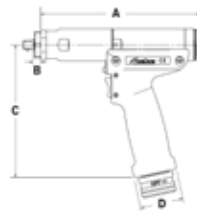

Rear Exit (4R) Model with Quick Change Output

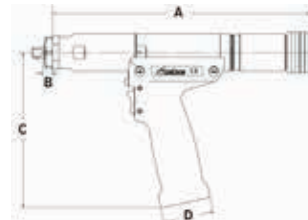

Top Exit (4T) Model



2000 Series Pistol Tools

Model	Max Torque		Torque Range		Free Speed Rpm	Weight (-) Socket Lb Kg		Output Sq Dr	(A)		(B)		(C)		(D)	
	Nm	Ft-Lb	Nm	Ft-Lb		In	Mm		In	Mm	In	Mm	In	Mm		
Pistol Tools	4A Models = Bottom Exit		4R Models = Rear Exit		4T Models = Top Exit		(V) = Extended Ergo-Drive Output									
AEP4(A)(R)(T)22020B(V)	20	14	5 - 20	3.7 - 14	1,313	2.4	1.09	3/8"	A = 7.82 R = 10.65 T = 9.71	198.7 270.6 246.5	0.38	9.7	A = 6.94 R = 6.01 T = 6.01	176.2 152.6 152.6	1.96	49.7
AEP4(A)(R)(T)22025B(V)	25	18	6.3 - 25	4.6 - 18	1,037	2.4	1.09	3/8"	A = 7.82 R = 10.65 T = 9.71	198.7 270.6 246.5	0.38	9.7	A = 6.94 R = 6.01 T = 6.01	176.2 152.6 152.6	1.96	49.7
AEP4(A)(R)(T)22030B(V)	30	22	7.5 - 30	5.5 - 22	840	2.4	1.09	3/8"	A = 7.82 R = 10.65 T = 9.71	198.7 270.6 246.5	0.38	9.7	A = 6.94 R = 6.01 T = 6.01	176.2 152.6 152.6	1.96	49.7
AEP4(A)(R)(T)22035B(V)	35	25	8.8 - 35	6.5 - 25	747	2.4	1.09	3/8"	A = 7.82 R = 10.65 T = 9.71	198.7 270.6 246.5	0.38	9.7	A = 6.94 R = 6.01 T = 6.01	176.2 152.6 152.6	1.96	49.7
AEP4(A)(R)(T)22040B(V)	40	29	10 - 40	7.4 - 29	656	2.4	1.09	3/8"	A = 7.82 R = 10.65 T = 9.71	198.7 270.6 246.5	0.38	9.7	A = 6.94 R = 6.01 T = 6.01	176.2 152.6 152.6	1.96	49.7

*Ergo logo indicates where ERGO-DRIVE sockets/extensions benefit tool operation.

2000 Series Angle and Inline Tools

Gen IV Series Angle and Inline Nutrunners

Smart, Rugged, and Cost-Effective: The New Leader in Accurate Fastening



FEATURES AND BENEFITS

- New robust design is lighter, slimmer, and more ergonomic than previous Gen III nutrunners
- One of the lowest total cost of ownership in the industry
- Ergonomic updated trigger design integrates trigger to tool body, requiring a shorter activation stroke
- Indexable head optimizes trigger position
- Smooth-grip handle
- Short length means easier tool positioning
- Backward compatible with all Gen III and Gen IV AcraDyne controllers

2000 Series Angle & Inline Tools

Model	Torque Range		Free Speed RPM	Weight (-) Socket		Output SQ DR	(A)		(B)		(C)		(D)		(E)		(F)		
	NM	FT-LB		LB	KG		MM	IN	MM	IN	MM	IN	MM	IN	MM	IN	MM	IN	
Angle Tools		(V)= Extended Ergo-Drive Output			(DL)= Dual Lever														
AEN4C22014C	3.5 - 14	2.6 - 10.3	1750	2.7	1.2	3/8	397	15.6	32	1.3	59.4	2.3	43.3	1.7	160	6.3	20.9	0.8	
AEN4C22024C	6 - 24	4.4 - 17.7	875	2.7	1.2	3/8	397	15.6	32	1.3	59.4	2.3	43.3	1.7	160	6.3	20.9	0.8	
AEN4F22029C	7.3 - 29	5.4 - 21.4	788	3.2	1.5	3/8	419	16.5	33.4	1.3	79.8	3.1	43.3	1.7	160	6.3	29.4	1.16	
AEN4F22036C	9 - 36	6.6 - 26.6	622	3.2	1.5	3/8	419	16.5	33.4	1.3	79.8	3.1	43.3	1.7	160	6.3	29.4	1.16	
AEN4F22043C(VDL)	10.8 - 43	8 - 31.7	504	3.2	1.5	3/8	419	16.5	33.4	1.3	79.8	3.1	43.3	1.7	160	6.3	29.4	1.16	
AEN4F22055C(V)	13.8 - 55	10.2 - 40.6	394	3.2	1.5	3/8	419	16.5	33.4	1.3	79.8	3.1	43.3	1.7	160	6.3	29.4	1.16	
Inline Tools (Includes Reaction Bar and Fixture Nut)																			
AES4A22020CV	5 - 20	3.7 - 14.8	1,313	2.8	1.3	3/8	401	15.8	95.9	3.8	109.5	4.3	43.3	1.7	160	6.3	381	15	
AES4A22025CV	6.3 - 25	4.6 - 18.4	1,037	2.8	1.3	3/8	401	15.8	95.9	3.8	109.5	4.3	43.3	1.7	160	6.3	381	15	
AES4A22030CV	7.5 - 30	5.5 - 22.1	840	2.8	1.3	3/8	401	15.8	95.9	3.8	109.5	4.3	43.3	1.7	160	6.3	381	15	
AES4A22035CV	8.8 - 35	6.5 - 25.8	747	2.8	1.3	3/8	401	15.8	95.9	3.8	109.5	4.3	43.3	1.7	160	6.3	381	15	
AES4A22040CV	10 - 40	7.4 - 29.5	656	2.8	1.3	3/8	401	15.8	95.9	3.8	109.5	4.3	43.3	1.7	160	6.3	381	15	

Angle Tool Dimensions



Inline Tool Dimensions



2000 Series Tubenut Tools

- Durable tubenut head design
- Simple, one-touch back to open operation for maximum productivity
- Innovative Sensor Technology: Transducer senses resistance in the initial 90 degrees of rotation and returns to open upon resistance encountered

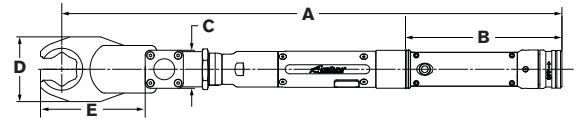
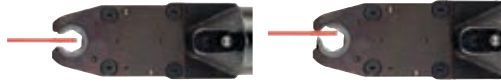

2000 Series Tubenut Tools

1000 Series	Torque Range		Free Speed RPM	Weight (-) Socket		Output Drive		A		B		C		D		E	
	NM	FT-LB		LB	KG	IN	MM	IN	MM	IN	MM	IN	MM	IN	MM	IN	MM
Tubenut	Wide variety of socket sizes available		(DL) = Dual Lever														
AET4AA22016C(DL)	4 - 16	3 - 11.8	1,828	4.1	1.86	1/4 - 7/16	7 - 12	19.1	484.3	6.5	164.4	1.6	40	1.5	37	2.2	56
AET4AB22021C(DL)	5.3 - 21	4 - 15.5	1,371	5.0	2.27	3/8 - 5/8	10 - 17	19.6	498.7	6.5	164.4	1.6	40	1.6	40	2.9	74
AET4AC22028C(DL)	7 - 28	5 - 20.7	1,020	5.5	2.49	1/2 - 7/8	13 - 24	20	508.4	6.5	164.4	1.6	40	2.2	56	3.5	88
AET4AD22038CDL	9.5 - 38	7 - 28	756	6.6	2.99	5/8 - 1-3/16	17 - 32	20.7	525.9	6.5	164.4	1.6	40	2.7	68	4.3	110

2000 Series Hold and Drive Tools

- 1" & 2" travel models available
- Sockets and holders are custom

1" Travel (C-1) Model

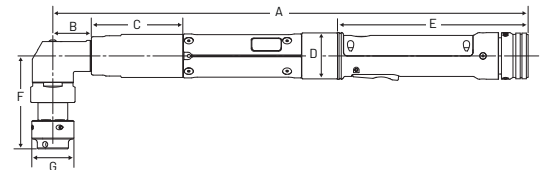

2000 Series Hold and Drive Tools

Model*	Max Torque		Torque Range		Free Speed RPM	Weight (LB)	Min Socket Max Socket	(A)		(B)		(C)		(D)		(E)		(F)		(G)	
	NM	FT-LB	NM	FT-LB				IN	MM	IN	MM	IN	MM	IN	MM	IN	MM	IN	MM	IN	MM
AEH4F22036C(-1)	36	27	7 - 36	5 - 27	871	-1 = 1.5 kg / 3.4 lb	9/16 (14 mm) 13/16 (21 mm)	16.2	412	1.3	33.4	3.2	80	1.6	40	6.5	165	-1 = 3.2	80.6	1.4	36.5
AEH4F22043C(-1)(-2)	43	32	9 - 43	7 - 32	705	-1 = 1.5 kg / 3.4 lb -2 = 1.7 kg / 3.7 lb	9/16 (14 mm) 13/16 (21 mm)	16.2	412	1.3	33.4	3.2	80	1.6	40	6.5	165	-1 = 3.2 -2 = 4.2	-1 = 80.6 -2 = 106	1.4	36.5
AEH4F22055C(-1)	55	41	11 - 55	8 - 41	551	-1 = 1.5 kg / 3.4 lb	9/16 (14 mm) 13/16 (21 mm)	16.2	412	1.3	33.4	3.2	80	1.6	40	6.5	165	-1 = 3.2	80.6	1.4	36.5

Hold & Drive (-1) = 1" Travel (-2) = 2" Travel

2000 Series Mid-Exit Tools

FEATURES AND BENEFITS

- Length
 - Reduced tool length due to cable exiting in front of grip surface
- Ergonomics
 - Reduced torque reaction compared to pistol-style tools
 - The inline handle, coupled with the ergonomic hand positioning, allows for increased leverage and decreased strain on the wrist
- Cable management
 - If used with a spring balancer, the tool hangs naturally near its center of gravity, the cable is controlled by the balancer
 - Front positioning of cable provides for easy cable management

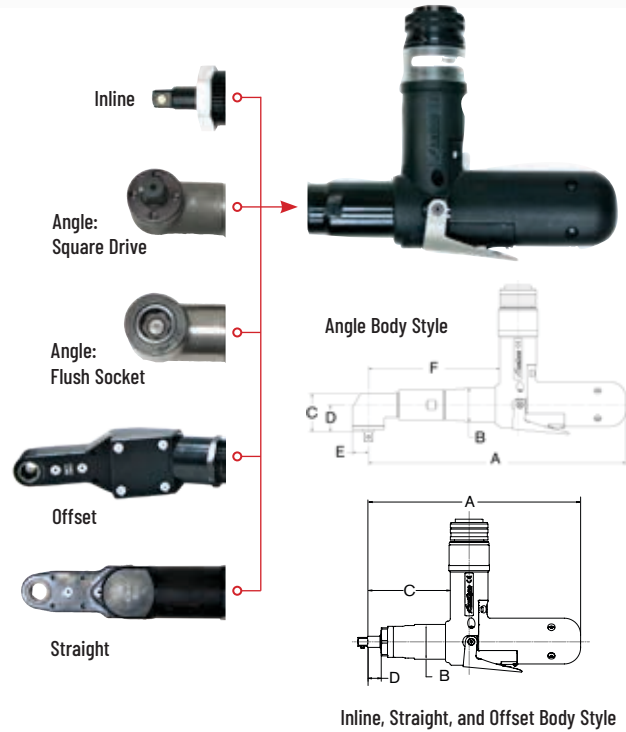

2000 Series Mid-Exit Cable Tools

Model	Max Torque		Torque Range		Free Speed RPM	Weight (-)Socket		Output SQ. DR.	A		B		C		D		E		F	
	NM	FT-LB	NM	FT-LB		LB	KG		IN	MM	IN	MM	IN	MM	IN	MM	IN	MM	IN	MM
Mid-Exit Models: Angle Body Style Add "F" to Part Numbers for Flush Socket																				
AEN4C22015BM(F)	15	11	3.75 - 15	2.77 - 11	700	2.6	1.18	3/8"	9.02	229.1	1.47	37.3	1.29	32.8	.82	20.9	.52	13.1	3.51	89.3
AEN4F22030BM(F)	30	22	7.5 - 30	5.53 - 22	675	3.3	1.50	3/8"	11.24	285.6	1.47	37.3	1.66	42.1	1.17	29.7	.70	17.8	5.73	145.6
AEN4F22037BM(F)	37	29	9.25 - 37	6.82 - 29	533	3.3	1.50	3/8"	11.24	285.6	1.47	37.3	1.66	42.1	1.17	29.7	.70	17.8	5.73	145.6
AEN4F22044BM(F)	44	32	11 - 40	8.11 - 29	432	3.3	1.50	3/8"	11.24	285.6	1.47	37.3	1.66	42.1	1.17	29.7	.70	17.8	5.73	145.6
Mid-Exit Models: Inline, Straight, and Offset Body Style																				
AES4A22020BVM	20	15	5 - 20	3.7 - 15	1050	2.4	1.09	3/8"	9.0	228.5	1.47	37.3	3.49	88.6	.56	14.2	—	—	—	—
AES4A22025BVM	25	18	6.3 - 25	4.6 - 18	830	2.4	1.09	3/8"	9.0	228.5	1.47	37.3	3.49	88.6	.56	14.2	—	—	—	—
AES4A22030BVM	30	22	7.5 - 30	5.5 - 22	672	2.4	1.09	3/8"	9.0	228.5	1.47	37.3	3.49	88.6	.56	14.2	—	—	—	—
AES4A22040BVM	40	30	10 - 40	7.4 - 30	525	2.4	1.09	3/8"	9.0	228.5	1.47	37.3	3.49	88.6	.56	14.2	—	—	—	—

Introducing AcraDyne's Discontinuous Drive Tool

AcraDrive

ONE TOOL

TWO WAYS TO DRIVE

Providing amazing flexibility in one tool, the AcraDyne Discontinuous Drive Nutrunner adds choice, speed, accuracy, and virtually reaction-free tightening to the user-friendly GEN IV Ecosystem



ONE TOOL, THREE TIGHTENING STRATEGIES

- Continuous Mode
 - Tool can be programmed to run in Continuous Mode like traditional DC nutrunners (within ergonomically acceptable limits)
- Discontinuous Mode
 - Virtually reaction-free performance with great accuracy and controllability
- Continuous Mode & Discontinuous Mode
 - Unique capability in a single tool delivers torque to the fastener in both Continuous and Discontinuous modes when programmed in a multistage parameter



DESIGNED + MADE IN THE USA

DISCONTINUOUS DRIVE ADVANTAGES

- High torque accuracy
- High tool speeds
- Minimal torque reaction as well as low vibration & noise
- One-handed operation
- Durable motor and gearing for long lifespan between preventative maintenance



Offering the greatest flexibility in one tool. The AcraDrive Discontinuous nutrunner offers three modes that are programmable in the Gen IV Controller. The ability to operate in Continuous Mode, Discontinuous Mode, or Continuous & Discontinuous Mode with one tool means ultimate cost savings with multiple features. No more need to sacrifice ergonomics for reduced cost of ownership, or forfeit high tool speeds in order to achieve traceable data.



FEATURES AND BENEFITS

Speed & Accuracy

- Combines fast tool speeds with Discontinuous drive and advanced data tracing
- Torque is measured by an industry standard Strain Gauge traceable transducer

Safe & Ergonomic Operation

- Optimal balance for less operator fatigue
- Minimal Torque Reaction Properties in Discontinuous Mode
- Proprietary Motor Control Algorithm for Optimizing to Application Demands

Low Maintenance

- Precision Gearing tested to greater than 500,000 cycle reliability
- Sealed Brushless Optimized Motors with zero maintenance requirements

Flexibility & Cost Savings

- Connects to the industry's most intuitive control platform – AcraDyne's iEC Gen IV Controller
- One tool capable of Continuous and Discontinuous drive means that one tool can cover more applications
- No software add-ons required and no-cost updates available at www.aimco-global.com



2000 Series Discontinuous Drive Tools

Model	Torque Range		Max Speed RPM	Joints		Length		Weight		Output Sq. Drive
	NM	FT-LB		Hard	Medium	IN	MM	LB	KG	
AEP4P22030AV	18 - 30	13.3 - 22	1,579	20 - 80°	80 - 150°	10.6	270	4.05	1.84	3/8"
AEP4P22050AV	28 - 50	20.7 - 37	1,579	20 - 80°	80 - 150°	10.7	273	4.05	1.84	1/2"

3000 SERIES

10 – 600 Nm

- Superior size, speed, and duty cycle compared to competitors' tools
- Aluminum gear and motor housing
- Onboard lights and audible signal for operator feedback



3000 Series Angle Tools

- Provides the perfect solution for space-limited applications
- Compact, durable head houses a precision right-angle gearset that fits into the tightest spaces
- Integrated transducer for accurate delivery or monitoring of Torque and Angle
- Lightweight materials and uniform body diameter provide a comfortable grip
- Ergonomically placed start lever for ease of operation
- Available in regular or flush socket options
- Dual-Lever available on 60 – 375 Nm models

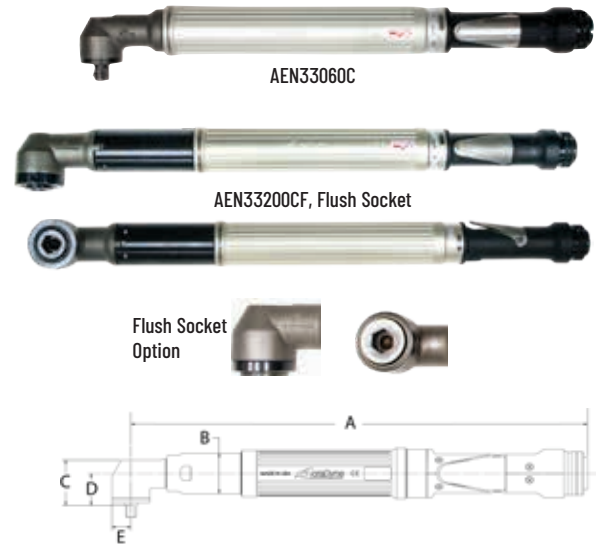

3000 Series Angle Tools

Model	Max Torque		Torque Range		Free Speed RPM	Weight (-)Socket		Output SQ. DR	(A)		(B)		(C)		(D)		(E)	
	NM	FT-LB	NM	FT-LB		LB	KG		IN	MM	IN	MM	IN	MM	IN	MM	IN	MM
3000 Series	Add "F" to Part Numbers for Flush Socket				DL = Dual Lever		(V) = Extended Ergo-Drive Output		W = Wobble Output Spindle									
AEN33060C(F)(DL)	60	44	12 - 60	9 - 44	845	6.6	2.99	1/2.	19.14	486.14	1.85	47	1.91	48.36	1.38	35.2	.83	21
AEN33090C(F)(DL)(V)(W)	90	66	18 - 90	13 - 66	568	6.6	2.99	1/2.	19.14	486.14	1.85	47	1.91	48.36	1.38	35.2	.83	21
AEN33120C(F)(DL)	120	89	24 - 120	18 - 88	442	9.3	4.22	1/2	21.22	539	1.85	47	2.78	71	2.08	53	1.05	27
AEN33200C(F)(DL)	200	148	40 - 200	29 - 147	245	9.4	4.26	3/4	23.43	595	1.85	47	2.54	65	1.84	47	1.05	27
AEN33210C(DL)	210	155	50 - 210	37 - 155	234	10.0	4.54	3/4	23.8	604.5	1.85	47	2.97	75	2.04	52	1.25	32
AEN33300C(DL)	300	221	60 - 300	42 - 221	151	10.0	4.54	3/4	23.72	602	1.85	47	2.97	75	2.04	52	1.25	32
AEN33375C(DL)	375	277	75 - 375	55 - 276	151	10.0	4.54	3/4	23.72	602	1.85	47	2.97	75	2.04	52	1.25	32

3000 Series Inline Tools

- Compact and durable, AcraDyne 3000 Series inline nutrunners are the ideal choice for fixtured fastening applications
- A uniform body diameter and a hex-shaped mounting point allow for simple installation into fixtured plates
- User modifiable reaction bar included with in-line tools for use in handheld applications
- Standard Square Drive or extended Ergo Drive output available on all models

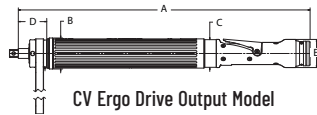

3000 Series Inline Tools

Model	Max Torque		Torque Range		Free Speed RPM	Weight (-) Socket		Output SQ. DR	(A)		(B)		(C)		(D)		(E)	
	NM	FT-LB	NM	FT-LB		LB	KG		IN	MM	IN	MM	IN	MM	IN	MM	IN	MM
3000 Series (V) = Extended Ergo-Drive Output -2 = 2" sliding spindle																		
AES33040C(V)(-2)	40	30	8 - 40	5.9 - 30	1,314	6.4	2.90	1/2"	V = 18.46 -2 = 23.89	469 606.8	1.96	49.8	V = 1.75 -2 = 1.85	44.5 47	V = 1.8 -2 = 4.3	45.7 109.5	1.78	45.2
AES33060C(V)(-2)	60	44	12 - 60	8.9 - 44	883	6.4	2.90	1/2"	V = 18.46 -2 = 23.89	469 606.8	1.96	49.8	V = 1.75 -2 = 1.85	44.5 47	V = 1.8 -2 = 4.3	45.7 109.5	1.78	45.2
AES33100C(V)(-2)	100	74	20 - 100	15 - 74	489	8.1	3.67	1/2"	V = 22.78 -2 = 27.71	578.6 703.8	1.96	49.8	V = 1.75 -2 = 1.85	44.5 47	V = 6.11 -2 = 3.96	155.3 100.5	1.78	45.2
AES33150C(V)(-2)	150	111	30 - 150	22 - 111	329	8.1	3.67	1/2"	V = 22.78 -2 = 27.71	578.6 703.8	1.96	49.8	V = 1.75 -2 = 1.85	44.5 47	V = 6.11 -2 = 3.96	155.3 100.5	1.78	45.2
AES33230C(V)(-2)	185	137	46 - 185	34 - 137	221	8.1	3.67	1/2"	V = 22.78 -2 = 27.71	578.6 703.8	1.96	49.8	V = 1.75 -2 = 1.85	44.5 47	V = 6.11 -2 = 3.96	155.3 100.5	1.78	45.2
AES33400C	400	295	80 - 400	59 - 295	122	13.0*	5.90*	3/4"			2.64	67.1	1.85	47	1.19	30.12	1.78	45.2
AES33600C	600	443	120 - 600	89 - 443	82	13.0*	5.90*	3/4"			2.64	67.1	1.85	47	1.19	30.12	1.78	45.2

* Includes reaction bar and fixture nut

3000 Series Hold and Drive Tools

- 1" & 2" travel models available
- Sockets and holders are custom



1" Travel
(C-1) Model

2" Travel
(C-2) Model

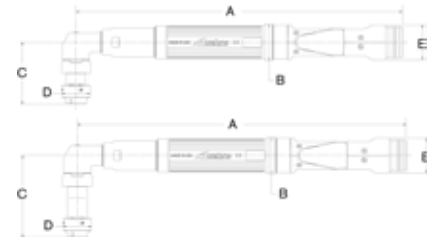

3000 Series Hold and Drive Tools

Model*	Max Torque		Torque Range		Free Speed RPM	Weight (LB)	Min Socket Max Socket	(A)		(B)		(C)		(D)		(E)	
	NM	FT-LB	NM	FT-LB				IN	MM	IN	MM	IN	MM	IN	MM	IN	MM
Hold & Drive (-1) = 1" Travel (-2) = 2" Travel																	
AEH33060C(-1)(-2)	60	44	12 - 60	9 - 44	845	-1 = 7.3 -2 = 7.5	9/16 (14 mm) 1-1/4 (32 mm)	19.1	485.1	1.85	47	-1 = 3.36 -2 = 4.37	85.3 111.1	1.88	47.6	1.78	45.2
AEH33090C(-1)(-2)	90	66	18 - 90	13 - 66	568	-1 = 7.3 -2 = 7.6	9/16 (14 mm) 1-1/4 (32 mm)	16.79	426.5	1.85	47	-1 = 3.36 -2 = 4.37	85.3 111.1	1.88	47.6	1.78	45.2
AEH33120C(-1)(-2)	120	89	24 - 120	18 - 89	442	-1 = 10.0 -2 = 10.3	5/8 (15 mm) 1-1/4 (32 mm)	21.22	539.1	1.85	47	-1 = 4.09 -2 = 5.09	103.8 129.2	2.25	57.2	1.78	45.2

* E logo indicates where ERGO-DRIVE sockets/extensions benefit tool operation.

5000 SERIES

20 – 635 Nm

- Superior size, speed, and duty cycle compared to competitors' tools
- High duty cycle
- Durable Nylon motor and handle housing
- Onboard lights and audible signal for operator feedback



5000 Series Pistol Tools

- Bottom and top exit models, as well as push-to start models available
- Ergo drive available on 75 – 170 Nm models
- Programmable Multi-Function Button: One single button facilitates several distinctly different tasks

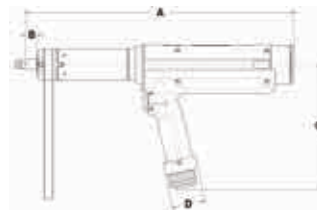

Extended Ergo Drive
Bottom Exit (AV) Model

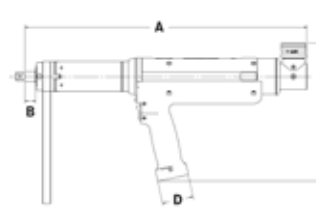

Extended Ergo Drive
Top Exit (AVT) Model

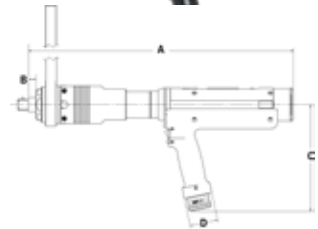

Standard Square Drive
Bottom Exit (A) Model

5000 Series Pistol Tools

Model	Max Torque		Torque Range		Free Speed RPM	Weight (-) Socket		Output SQ DR	(A)		(B)		(C)		(D)	
	NM	FT-LB	NM	FT-LB		LB	KG		IN	MM	IN	MM	IN	MM	IN	MM
5000 Series	V = Extended Ergo-Drive Output		T = Top Exit Models													
AEP35075AV(T)	75	55	19 - 75	14 - 55	944	9.2	4.17	1/2	AV = 15.95 AVT = 16.83	405.2 427.4	.68	17.4	AV = 7.44 AVT = 8.63	188.9 219	1.96	49.7
AEP35090AV(T)	90	66	23 - 90	17 - 66	767	9.2	4.17	1/2	AV = 15.95 AVT = 16.83	405.2 427.4	.68	17.4	AV = 7.44 AVT = 8.63	188.9 219	1.96	49.7
AEP35110AV(T)	110	81	28 - 110	21 - 81	634	9.2	4.17	1/2	AV = 15.95 AVT = 16.83	405.2 427.4	.68	17.4	AV = 7.44 AVT = 8.63	188.9 219	1.96	49.7
AEP35135AV(T)	135	99	34 - 135	25 - 99	515	9.2	4.17	1/2	AV = 15.95 AVT = 16.83	405.2 427.4	.68	17.4	AV = 7.44 AVT = 8.63	188.9 219	1.96	49.7
AEP35170AV(T)	170	125	43 - 170	32 - 125	418	9.2	4.17	1/2	AV = 15.95 AVT = 16.83	405.2 427.4	.68	17.4	AV = 7.44 AVT = 8.63	188.9 219	1.96	49.7
AEP35280A(T)	280	206	70 - 280	52 - 207	236	13.6	6.17	3/4	A = 18.51 AT = 19.41	470.3 493.1	.52	13.1	A = 7.44 AT = 8.59	188.9 217.9	1.96	49.7
AEP35350A(T)	350	258	88 - 350	65 - 258	192	13.6	6.17	3/4	A = 18.51 AT = 19.41	470.3 493.1	.52	13.1	A = 7.44 AT = 8.59	188.9 217.9	1.96	49.7
AEP35420A(T)	420	310	105 - 420	78 - 310	159	13.6	6.17	3/4	A = 18.51 AT = 19.41	470.3 493.1	.52	13.1	A = 7.44 AT = 8.59	188.9 217.9	1.96	49.7
AEP35515A(T)	515	380	128 - 515	95 - 380	129	13.6	6.17	3/4	A = 18.51 AT = 19.41	470.3 493.1	.52	13.1	A = 7.44 AT = 8.59	188.9 217.9	1.96	49.7
AEP35635A(T)(R)	635	468	159 - 635	117 - 469	104	13.6	6.17	3/4	A = 18.51 AT = 19.41	470.3 493.1	.52	13.1	A = 7.44 AT = 8.59	188.9 217.9	1.96	49.7

* E logo indicates where ERGO-DRIVE sockets/extensions benefit tool operation.

5000 Series Angle Tools

- Provides the perfect solution for space-limited applications. Compact, durable head houses a precision right-angle gearset that fits into the tightest spaces
- Integrated transducer for accurate delivery or monitoring of Torque and Angle
- Lightweight materials and uniform body diameter provide a comfortable grip
- Ergonomically placed start lever for ease of operation
- Available in regular or flush socket options

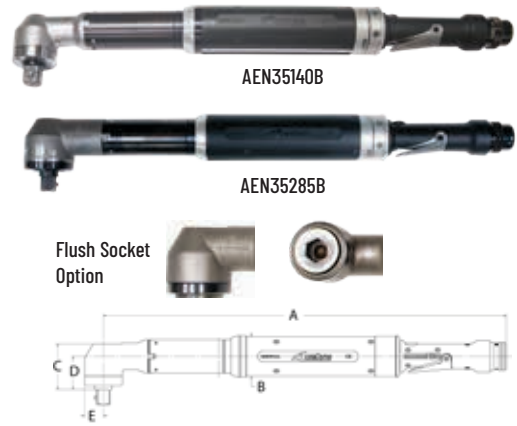

5000 Series Angle Tools

Model	Max Torque		Torque Range		Free Speed RPM	Weight (-) Socket		Output SQ. DR	(A)		(B)		(C)		(D)		(E) B models only		
	NM	FT-LB	NM	FT-LB		LB	KG		IN	MM	IN	MM	IN	MM	IN	MM	IN	MM	
5000 Series	Add "F" to Part Numbers for Flush Socket																		
AEN35090B(F)	90	66	23 - 90	17 - 66	607	6.9	3.13	1/2	22.63	574.8	2.31	58.7	1.91	48.6	1.38	35.2	.81	20.6	
AEN35140B(F)	140	103	35 - 140	26 - 103	472	10.4	4.72	3/4	22.56	573	2.31	58.7	2.54	64.6	1.84	46.8	1.05	26.7	
AEN35175B(F)	175	129	44 - 175	33 - 129	384	10.5	4.76	3/4	22.56	573	2.31	58.7	2.54	64.6	1.84	46.8	1.05	26.7	
AEN35210BF	210	155	52 - 210	38 - 155	317	12.3	5.58	3/4	22.56	573	2.31	58.7	2.4	61	1.7	43.2	-	-	
AEN35225B(F)	225	166	56 - 225	41 - 166	291	12.3	5.58	3/4	22.92	582.2	2.31	58.7	2.86	72.6	1.94	49.1	1.25	31.8	
AEN35285B(F)	285	210	71 - 285	52 - 210	236	12.3	5.58	3/4	22.92	582.2	2.31	58.7	2.86	72.6	1.94	49.1	1.25	31.8	
AEN35350B(F)	350	258	88 - 350	65 - 258	191	12.3	5.58	3/4	22.92	582.2	2.31	58.7	2.86	72.6	1.94	49.1	1.25	31.8	

5000 Series Inline Tools

- Compact and durable, AcraDyne 5000 Series inline nutrunners are the ideal choice for fixtured fastening applications
- A uniform body diameter and a hex-shaped mounting point allow for simple installation into fixtured plates
- User modifiable reaction bar included with in-line tools for use in handheld applications
- Standard Square Drive or extended Ergo Drive output available on all models



5000 Series Inline Tools

Model	Max Torque		Torque Range		Free Speed RPM	Weight (-) Socket		Output Sq. Dr	(A)		(B)		(C)		(D)		(E)		
	NM	FT-LB	NM	FT-LB		LB	KG		IN	MM	IN	MM	IN	MM	IN	MM	IN	MM	
5000 Series	V = Extended Ergo-Drive Output																		
AES35075AV	75	55	19 - 75	14 - 55	944	9.2	4.17	1/2	21.9	556.3	1.85	47	2.31	58.7	.68	17.4	1.78	45.2	
AES35090AV	90	66	23 - 90	17 - 66	767	9.2	4.17	1/2	21.9	556.3	1.85	47	2.31	58.7	.68	17.4	1.78	45.2	
AES35110AV	110	81	28 - 110	21 - 81	634	9.2	4.17	1/2	21.9	556.3	1.85	47	2.31	58.7	.68	17.4	1.78	45.2	
AES35135AV	135	100	34 - 135	25 - 100	515	9.2	4.17	1/2	21.9	556.3	1.85	47	2.31	58.7	.68	17.4	1.78	45.2	
AES35170AV	170	126	43 - 170	32 - 126	418	9.2	4.17	1/2	21.9	556.3	1.85	47	2.31	58.7	.68	17.4	1.78	45.2	
AES35280A	280	207	70 - 280	52 - 207	236	12.8	5.81	3/4	24.33	618.2	2.31	58.7	2.64	67.1	.52	13.1	1.78	45.2	
AES35350A	350	258	88 - 350	65 - 258	192	12.8	5.81	3/4	24.33	618.2	2.31	58.7	2.64	67.1	.52	13.1	1.78	45.2	
AES35420A	420	310	105 - 420	78 - 310	159	12.8	5.81	3/4	24.33	618.2	2.31	58.7	2.64	67.1	.52	13.1	1.78	45.2	
AES35515A	515	380	128 - 515	95 - 380	129	12.8	5.81	3/4	24.33	618.2	2.31	58.7	2.64	67.1	.52	13.1	1.78	45.2	
AES35635A	635	469	159 - 635	117 - 469	104	12.8	5.81	3/4	24.33	618.2	2.31	58.7	2.64	67.1	.52	13.1	1.78	45.2	

*E logo indicates where ERGO-DRIVE sockets/extensions benefit tool operation.

5000 Series Fixtured Tools

- Rear & bottom exit available
- Standard Square Drive, Extended Ergo Drive, or 1/4" Quick Change outputs available in most models
- Models available with 1/2" fixed sq. dr., 3/4" fixed sq. dr., and 2" sliding spindle



AEF35135AV
Extended Ergo Drive, Rear Exit Model



AEF35350A
Standard Spindle, Rear Exit Model



AEF35135AVB
Extended Ergo Drive, Bottom Exit Model



AEF35135A-2
2" Sliding Spindle, Rear Exit Model



AEF35135AB-2
2" Sliding Spindle, Bottom Exit Model

5000 Series Fixtured Tools

Model	Max Torque		Torque Range		Free Speed RPM	Weight (-)Socket		Output SQ. DR.
	NM	FT-LB	NM	FT-LB		LB	KG	
5000 Series	(V) = Extended Ergo Drive Output		(VB) = Extended Output with Bottom Exit Cable			(B) = Bottom Exit Cable		
	(-2) = 2" Sliding Spindle with Rear Exit Cable		(B-2) = 2" Sliding Spindle with Bottom Exit Cable					
AEF35075A(V)(VB)(-2)(B-2)	75	55	19 - 75	14 - 55	944	9.6	4.35	1/2"
AEF35090A(V)(VB)(-2)(B-2)	90	66	23 - 90	17 - 66	767	9.6	4.35	1/2"
AEF35110A(V)(VB)(-2)(B-2)	110	81	28 - 110	21 - 81	634	9.6	4.35	1/2"
AEF35135A(V)(VB)(-2)(B-2)	135	100	34 - 135	25 - 100	515	9.6	4.35	1/2"
AEF35170A(V)(VB)	170	125	43 - 170	32 - 125	418	9.6	4.35	1/2"
AEF35170A(-2)(B-2)	170	125	43 - 170	32 - 125	418	9.6	4.35	3/4"
AEF35280A*	280	207	70 - 280	52 - 207	236	13.6	6.17	3/4"
AEF35350A*	350	258	88 - 350	65 - 258	192	13.6	6.17	3/4"
AEF35420A*	420	310	105 - 420	77 - 310	159	13.6	6.17	3/4"
AEF35515A*	515	380	128 - 515	95 - 380	129	13.6	6.17	3/4"
AEF35635A*	635	469	159 - 635	117 - 469	104	13.6	6.17	3/4"

* Item 28843 is a panel mount 2" sliding spindle for 280 - 635 Nm models.

5000 Series Fixtured Tool Dimensions

MODEL	(A)		(B)		(C)		(D)		(E)		(F)		(G)	
	IN	MM	IN	MM	IN	MM	IN	MM	IN	MM	IN	MM	IN	MM
AEF35075AV	18.04	458.2	11.55	293.3	1.85	47	1.75	44.4	6.92	175.9	1.56	39.6	.72	18.4
AEF35090AV	18.04	458.2	11.55	293.3	1.85	47	1.75	44.4	6.92	175.9	1.56	39.6	.72	18.4
AEF35110AV	18.04	458.2	11.55	293.3	1.85	47	1.75	44.4	6.92	175.9	1.56	39.6	.72	18.4
AEF35135AV	18.04	458.2	11.55	293.3	1.85	47	1.75	44.4	6.92	175.9	1.56	39.6	.72	18.4
AEF35170AV	18.04	458.2	11.55	293.3	1.85	47	1.75	44.4	6.92	175.9	1.56	39.6	.72	18.4
AEF35075A-2	23.48	596.3	11.55	293.3	1.85	47	1.75	44.4	6.92	175.9	1.59	40.4	2.23	56.6
AEF35090A-2	23.48	596.3	11.55	293.3	1.85	47	1.75	44.4	6.92	175.9	1.59	40.4	2.23	56.6
AEF35110A-2	23.48	596.3	11.55	293.3	1.85	47	1.75	44.4	6.92	175.9	1.59	40.4	2.23	56.6
AEF35135A-2	23.48	596.3	11.55	293.3	1.85	47	1.75	44.4	6.92	175.9	1.59	40.4	2.23	56.6
AEF35170A-2	23.48	596.3	11.55	293.3	1.85	47	1.75	44.4	6.92	175.9	1.59	40.4	2.23	56.6
AEF35280A	20.48	520.2	11.55	293.3	2.14	54.4	2.64	67.1	9.28	235.7	1.56	39.6	.52	13.1
AEF35350A	20.48	520.2	11.55	293.3	2.14	54.4	2.64	67.1	9.28	235.7	1.56	39.6	.52	13.1
AEF35420A	20.48	520.2	11.55	293.3	2.14	54.4	2.64	67.1	9.28	235.7	1.56	39.6	.52	13.1
AEF35515A	20.48	520.2	11.55	293.3	2.14	54.4	2.64	67.1	9.28	235.7	1.56	39.6	.52	13.1
AEF35635A	20.48	520.2	11.55	293.3	2.14	54.4	2.64	67.1	9.28	235.7	1.56	39.6	.52	13.1

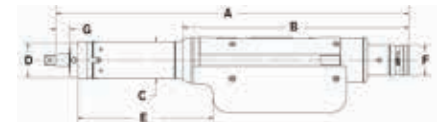

Extended Ergo Drive Output (AV) Models

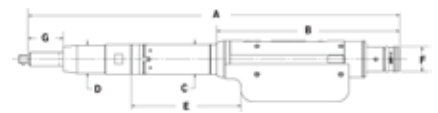

2" Sliding Spindle (A-2) Models

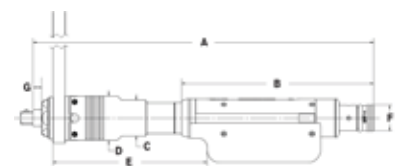

Standard Spindle (A) Models

* E logo indicates where ERGO-DRIVE sockets/extensions benefit tool operation.

5000 Series Hold-and-Drive Tools

- Torques ranging from 90 Nm – 350 Nm
- Very robust design
- 1" and 2" travels are standard
- Sockets and holders are custom

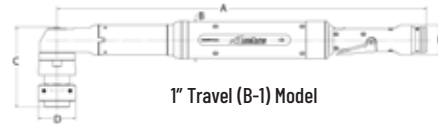

1" Travel (B-1) Model

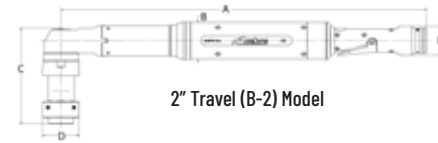

2" Travel (B-2) Model

5000 Series Hold and Drive Tools

Model*	Max Torque		Torque Range		Free Speed RPM	Weight (LB)	Min Socket	Max Socket	(A)		(B)		(C)		(D)		(E)	
	NM	FT-LB	Nm	FT-LB					IN	MM	IN	MM	IN	MM	IN	MM	IN	MM
AEH35090B(-1)(-2)	90	66	23 - 90	17 - 66	607	-1 = 7.6 -2 = 7.9	9/16 (14 mm) 1-1/4 (32 mm)		22.63	574.8	2.31	58.7	-1 = 4.02 -2 = 4.96	102.1 126	1.88	47.6	1.78	45.2
AEH35140B(-1)(-2)	140	103	35 - 140	26 - 103	472	-1 = 10.6 -2 = 11.0	5/8 (15 mm) 1-1/4 (32 mm)		22.56	572.9	2.31	58.7	-1 = 4.87 -2 = 5.87	123.7 149.1	2.25	57.15	1.78	45.2
AEH35175B(-1)(-2)	175	129	44 - 175	33 - 129	384	-1 = 10.6 -2 = 11.1	5/8 (15 mm) 1-1/4 (32 mm)		22.52	571.9	2.31	58.7	-1 = 4.87 -2 = 5.87	123.7 149.1	2.25	57.15	1.78	45.2
AEH35225B(-1)(-2)	225	166	56 - 225	41 - 166	291	-1 = 12.9 -2 = 13.3	3/4 (19 mm) 1-1/4 (32 mm)		22.92	582.2	2.31	58.7	-1 = 5.52 -2 = 6.52	140.1 165.5	2.63	66.7	1.78	45.2
AEH35285B(-1)(-2)	285	210	71 - 285	52 - 210	236	-1 = 12.9 -2 = 13.3	3/4 (19 mm) 1-1/4 (32 mm)		22.92	582.2	2.31	58.7	-1 = 5.52 -2 = 6.52	140.1 165.5	2.63	66.7	1.78	45.2
AEH35350B(-1)(-2)	350	258	88 - 350	65 - 258	191	-1 = 12.9 -2 = 13.3	3/4 (19 mm) 1-1/4 (32 mm)		22.92	582.2	2.31	58.7	-1 = 5.52 -2 = 6.52	140.1 165.5	2.63	66.7	1.78	45.2

SPECIALTY GEARHEADS

AIMCO can provide specialized heads for most any application. Tubenut, Hold and Drive, Crow Foot, Offsets, and Sliding Spindles are just a few of the head styles available. Whatever the requirements, AIMCO will recommend the head configuration that will get the job done successfully.

Contact an AIMCO Customer Service Associate for more details, 1-503-254-6600, or toll free 1-800-852-1368.

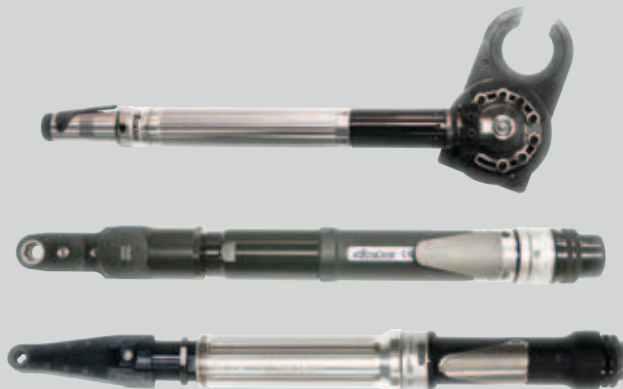

AcraDyne Riv-Nut Tools

AcraDyne Riv-Nut Tools

Offering the same size, speed, and duty cycle benefits of 1000 and 2000 series tools, AcraDyne's Riv-Nut tools have a simple, quick mandrel change design and are suitable for a wide range of material thicknesses – limited only by rivet nut size.

FEATURES AND BENEFITS

- Pull-to-torque tool/controller system ensures accurate, repeatable, and measurable tightening every time
- 1000 & 2000 series tools available with bottom exit, rear exit, or top exit cable configurations. Fixtured, and Push-to-Start models are available by request. Contact AIMCO at 1-503-254-6600, or toll free 1-800-852-1368
- Low-friction coating on mandrel for extended life
- Precise control of rivet compression with Torque and Angle detection capability
- Data collection and networking capabilities to capture and utilize result data for QMS systems and line controls
- Multi-function button (MFB) provides increased flexibility
- On-board lights and audible signal for operator feedback
- Works with rivet sizes M4 – M10 or 8-32 – 3/8-16



1000 & 2000 Series Riv-Nut Tools

Model*	Torque Range		Free Speed RPM	Weight (-) Socket		Thread Size	Dimensions								
	NM	FT-LB		LB	KG		(A) IN	(A) MM	(B) IN	(B) MM	(C) IN	(C) MM	(D) IN	(D) MM	
Pistol															
1000 Series	4A Models = Bottom Exit		4R Models = Rear Exit	4T Models = Top Exit											
AEP4(A)(R)I2006BR	1.5 - 6	1.1 - 4.4	2,625	2.2	1.00	M4 x 0.7 mm M5 x 0.8 mm	8-32 UNC 10-24 UNC	9.68	245.9	1.05	26.7	6.01	152.6	1.96	49.8
AEP4(A)(R)I2014BR	3.5 - 14	2.6 - 10	1,037	2.3	1.04	M6 x 1.0 mm M8 x 1.25 mm	10-32 UNF 1/4-20 UNC	9.68	245.9	1.05	26.7	6.87	174.5	1.96	49.8
AEP4(A)(R)I2022BR	5.5 - 22	4.1 - 16	656	2.3	1.04	M10 x 1.5 mm	5/16-18 UNC 3/8-16 UNC	9.68	245.9	1.05	26.7	6.87	174.5	1.96	49.8
2000 Series	4A Models = Bottom Exit		4R Models = Rear Exit	4T Models = Top Exit											
AEP4(A)(R)(T)22020BR	5 - 20	3.7 - 15	1,313	2.4	1.09	M4 x 0.7 mm M5 x 0.8 mm	8-32 UNC 10-24 UNC	10.18	258.6	1.05	26.7	6.87	174.5	1.96	49.8
AEP4(A)(R)(T)22030BR	7.5 - 30	5.5 - 22	840	2.4	1.09	M6 x 1.0 mm M8 x 1.25 mm	10-32 UNF 1/4-20 UNC	10.18	258.6	1.05	26.7	6.87	174.5	1.96	49.8
AEP4(A)(R)(T)22040BR	10 - 40	7.4 - 30	656	2.4	1.09	M10 x 1.5 mm	5/16-18 UNC 3/8-16 UNC	10.18	258.6	1.05	26.7	6.87	174.5	1.96	49.8
Straight															
2000 Series															
AES4A22020CR	5 - 20	3.7 - 14.8	1,313	2.8	1.3	M4 x 0.7 mm M5 x 0.8 mm	8-32 UNC 10-24 UNC	16.4	417.3	1.7	43.2	7.04	178.7	1.38	34.9
AES4A22040CR	10 - 40	7.4 - 29.5	656	2.8	1.3	M6 x 1.0 mm M8 x 1.25 mm	10-32 UNF 1/4-20 UNC	16.4	417.3	1.7	43.2	7.04	178.7	1.38	40.4

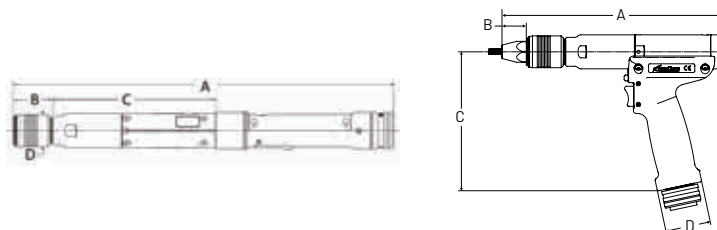

AcraDyne High Torque DC Tools

Critical bolting demands tools that deliver high torque with superior performance. Couple with AcraDyne's Controller, the HT Series tools combine these features in an electric, high-torque bolting system that beats the competition in accuracy, speed, and safety.

FEATURES AND BENEFITS

- Built-in integral transducer for optimal monitoring and control
- One of the most accurate high-torque tools in the world
- 250 Nm – 17,000 Nm torque range
- Ergonomic, robust design with five handle configurations that are also available in dual-lever models
- The world's most advanced traceable system at the output
- Three tightening strategies:
 - *Torque Control*: Drive the tool to a pre-set Target Torque
 - *Angle Control*: Drive the tool to or measure a pre-set Degree of Angle
 - *Yield Control*: Drive the tool to the Fastener Yield Point to achieve maximum clamp load
- Data retrieval
- Optional rugged carrying/storage case available
- Optional tool fan available in models 8,100 NM and above
- **DESIGNED AND ASSEMBLED IN THE USA**



Pistol Type (AEP)



Axial Type (AEJ)



Straight Lever Type (AES)

HT Fixed Gearcase Tools

Model	Approx. Torque NM FT-LB		Approx. Speed RPM	Weight KG LB		Total Length (incl sq. dr) MM IN		Dia. MM IN	Drive IN	Sound Level dB(A)	
HT Series Fixed Gearcase Models (R) = Pistol Tool with Rear Exit Cable (B) = Fixtured Model with Bottom Exit Cable											
6000 Series											
AE (P) 4A66250B (R) AE (D) (S) (J) (F) 4A66250B	250	185	315	4.6	10.5	P = 289 D = 388 S = 440	11.4 13 15.3	66	2.6	0.75	66
AE (P) 4A66425B (R) AE (D) (S) (J) 4A66425B AE (F) 4A66425B (B)	425	315	165	4.6	10.5	J = 331 F = 331	13 13	66	2.6	0.75	66
AE (P) A66625B (R) AE (D) (S) (J) 4A66625B AE (F) 4A66625B (B)	625	460	106	4.8	10.5	F (B) = 353	13 13.9	66	2.6	0.75	66
AE (P) 4A66925B (R) AE (D) (S) (J) (F) 4A66925B	925	682	72	4.8	10.5			66	2.6	0.75	66
7000 Series											
AE (F) 4A76200BB	200	148	432	5.2	11.5	313	12.3	67.3	2.7	0.75	66
AE (P) (D) (S) (J) (F) 4A771000B	1,000	738	65	6.6	14.5	P = 302 D = 397 S = 453 J = 343 F = 343	11.9 15.6 17.8 13.5 13.5	77.5	3.1	1	66
AE (P) (D) (S) (J) 4A772500B AE (F) 4A772500B (B)	2,500	1,844	25	7.5	16.5	P = 337 D = 433 S = 488 J = 379 F = 379	13.3 17.0 19.2 14.9 14.9	77.5	3.1	1	66
8000 Series											
AE (P) (D) (J) (F) 4A884200B1 AE (P) (D) (S) (J) (F) 4A884200B	4,200	3,100	12	11.1	24.5	P = 384 D = 480 S = 546	15.1 18.9 21.5	91.2	3.6	B1 = 1 B = 1.5	66
AE (P) (D) (J) (F) 4A885000B	5,000	3,700	9.3	11.1	24.5	J = 410 F = 410	16.1 16.1			1.5	66
AE (P) (D) (J) (F) 4A896500B AE (F) 4A896500B (B)	6,500	4,800	7	15.7	34.5	P = 438 D = 533 S = 599	17.2 21 23.6	103.8	4.1	1.5	66
AE (P) (D) (S) (J) (F) 4A898100B	8,100	6,000	5	15.7	34.5	J = 463 F = 462	18.2 18.2				



Rear Mounted Pistol (AED)



Fixtured Type (AEF)

* 8,100 Nm - 17,000 Nm models are not supported by the Gen III controller platform. The Gen IV controller platform is required.

AcraDyne High Torque DC Tools

360° Swivel Gearcase Nutrunners

FEATURES AND BENEFITS

- Same features and benefits of fixed gearcase models
- Ergonomic, robust design with two handle configurations



2,800 Nm Torque
AEP4W872800B



8,100 Nm Torque
AEJ4B898100B



8,100 Nm Torque
AEP4B898100B

HT 360° Swivel Gearcase Tools

Model	Approx. Torque NM	Approx. Torque FT-LB	Approx. Speed RPM	Weight KG	Weight LB	Length (incl sq. dr)		Dia.		Drive	Sound Level dB(A)
						MM	IN	MM	IN	IN	
HT Series 360° Swivel Gearcase Models (R) = Pistol Tool with Rear Exit Cable											
6000 Series											
AE (P) 4B66250B(R)	250	185	315	5.3	12	P = 327 P(R) = 368 D = 429 J = 369	12.9 14.5 16.9 14.5	67.3	2.7	0.75	66
AE (D)(J) 4B66250B											
AE (P) 4B66425B(R)	425	315	165	5.3	12						
AE (D)(J) 4B66425B											
AE (P) 4B66625B(R)	625	460	106	5.5	12						
AE (D)(J) 4B66625B											
AE (P) 4B66925B(R)	925	682	72	5.5	12						
AE (D)(J) 4B66925B											
7000 Series											
AE (P)(J) 4B771000B	1,000	738	65	7.3	16	P = 339 J = 381	13.4 15	77.5	3.1	1	66
AE (P)(J) 4B772500B	2,500	1,844	25	8.2	18	P = 377 J = 418	14.8 16.5				
8000 Series											
AE (P)(D)(J) 4B884200B1	4,200	3,100	12	11.8	26	P = 422 D = 518 J = 446	16.6 20.4 17.6	91.2	3.6	B1 = 1 B = 1.5	66
AE (P)(D)(J) 4B884200B											
AE (P)(J) 4B896500B	6,500	4,800	7	16.4	36	P = 475 J = 499	18.7 19.7	103.8	4.1	1.5	66
AE (P)(D)(J) 4B898100B*	8,100	6,000	5	16.4	36	P = 475 D = 571 J = 499	18.7 22.5 19.7	103.8	4.1	1.5	66
AE (P) 4B998100B*	8,100	6,000	5	21.8	48	532	20.9	112	4.4	1.5	66
Models for Extreme Duty / Low Power Environments											
Wind Series											
AE (P)(J) 4W872800B	2,800	2,065	9	10.0	22	P = 406 J = 430	16 17	76	3.0	1	66
AE (P)(D)(J) 4W885000B1*	5,000	3,700	4.5	11.8	26	P = 422 D = 518 J = 446	16.6 20.4 17.6	91.2	3.6	B1 = 1 B = 1.5	66
AE (P)(D)(J) 4W885000B*											

* 8,100 Nm - 17,000 Nm models are not supported by the Gen III controller platform. The Gen IV controller platform is required.

AIMCO can provide customized tooling solutions for even the most unique applications. Let us propose a solution tailored to your needs. Contact an AIMCO Customer Service Associate for more details, 1-503-254-6600, or toll free 1-800-852-1368.

AcraDyne High Torque DC Angle Tools

AcraDyne HT DC Angle Tools provide the perfect solution for space-limited applications. Compact, durable head houses a precision right-angle gearset that fits into the tightest spaces

FEATURES AND BENEFITS

- Transducerized closed loop control at the output like all AcraDyne HT-Series tools
- These low-profile head, small-diameter, lever-operated tools, with the torque measured at the output, offer a unique solution
- The torque reported is the torque delivered
- One of the most accurate high-torque right-angle tools in the world
- Smallest tools of their kind on the market
- Same durable, high-cycle gearing as all HT-series tools
- These models are fixtured tools



AEN356540A



AEN3571000A



AEN356910AG



AEN3571600A



AEN3572600A

5000 Series HT Angle Tools

MODEL	Max. Torque*		Torque Range		Free Speed RPM	Weight		Output SQ Drive	Dimensions									
	NM	FT-LB	NM	FT-LB		LB	KG		A		B		C		D		E	
									IN	MM	IN	MM	IN	MM	IN	MM	IN	MM
AEN356540A	540	398	135 - 540	100 - 398	109	13.1	5.95	3/4"	22.58	573.6	2.31	58.7	4.75	120.6	4.05	102.8	1.33	33.7
AEN356910AG	900	664	225 - 900	166 - 664	27.9	12.2	5.5	3/4"	18.2	462.9	2.31	58.7	5.93	150.6	4.93	125.2	1.28	32.6
AEN3571000A	1,000	737	250 - 1,000	184 - 737	61	16.3	7.39	1"	22.92	582.2	2.31	58.7	5.36	136.1	4.44	112.7	1.53	38.7
AEN3571600A	1,600	1,180	400 - 1,600	295 - 1,180	33	16.7	7.57	1"	22.92	582.2	2.31	58.7	5.36	136.1	4.44	112.7	1.53	38.7
AEN3572600A	2,600	1,917	650 - 2,600	479 - 1,917	21	18.5	8.40	1"	22.92	582.2	2.31	58.7	6.77	171.9	5.86	148.8	1.53	38.7

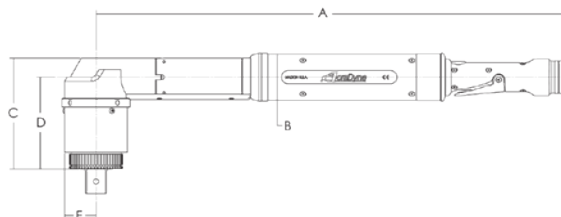

A BETTER ANGLE ON BIG JOBS



AcraDyne HT DC Angle Nutrunner is THE Tool for Servicing Blades on Wind Turbines



This **unique tool configuration**, built with all of the AcraDyne HT advantages, is made in a size that allows access to blade bolts that cannot be easily accessed by other continuous drive tools. The 360° swivel gearcase allows for precise placement of the tool reaction bar against reactive surfaces for ease of use.



AcraDyne High Torque DC Angle Tools

AcraDyne's HT DC angle nutrunner is one of the smallest tools of its kind on the market. A powerful motor combined with a short-length handle and a 360° swivel gearcase gives you ultimate flexibility in limited-space applications.

FEATURES AND BENEFITS

- Easy access to previously hard-to-reach blade bolts
- Faster speed than hydraulic tools
- Acquires data in both loosening and retightening directions
- Preset strategies and sequencing for ease of use
- Most intuitive user interface in the industry for setup and data transfer
- Slip ring gearbox for 360° reaction bar movement
- Dual-lever option available
- Measures traceable, dynamic torque directly at the square drive, and the built-in transducer ensures accurate torque values. The torque reported is the torque delivered
- One of the most accurate high-torque right-angle tools in the world
- Same durable, high-cycle gearing as AcraDyne's industry-leading HT series tools
- Available with an optional rugged, weather-resistant carrying case



Custom reaction bars available

7000 Series HT DC Angle Tools

Model*	Max. Torque		Torque Range		Free Speed RPM	Length (Minus Reaction Bar)		Weight		Output SQ DRIVE
	NM	FT-LB	NM	FT-LB		IN	MM	LB	KG	
AEN4B771200B(DL)	1,200	885	240 - 1,200	177 - 885	38	16.6	422	17.9	8.1	1"
AEN4B773000B(DL)	3,000	2,200	600 - 3,000	443 - 2,200	15	16.6	422	20.4	9.3	1"

* Add "DL" to Part Numbers for Dual Lever

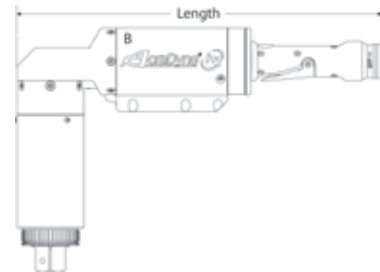

Gen IV iEC4W Field Controller: High Torque with High Tech

The Gen IV Field Controller (see page 40) is the core of the modular AcraDyne DC system. One controller will command any tool in the AcraDyne line – including the HT DC Angle Tool – from 1 Nm to 17,000 Nm, all with the same modular standard cable design.

AcraDyne High Torque DC Dual-Lever Tools

HIGH TORQUE DUAL-LEVER TOOLS

Provides Additional Safety by Avoiding Accidental Tool Start

FEATURES AND BENEFITS

- Built-in integral transducer for optimal monitoring and control
- One of the most accurate high-torque tools in the world
- 250 Nm - 17,000 Nm
- Two-Hand No Tie Down Operation
 - No Tie Down Control: Operator must have both hands on and activating the dual-starting mechanisms simultaneously. Both hands must remain in position, activating the dual controls, at all times in order for the tool to operate.
- Additional safety when using a tool with a reaction bar or nose extension. Operator's hands remain on the controls and not in a position where they could be impacted by reaction devices
- Hands stay clear of application
- Helps avoid accidental starting of the tool
- Available in Fixtured (F), J-Handle (J), Straight (S), as well as dual-handle configurations
- DESIGNED AND ASSEMBLED IN THE USA



AEJ Type



AEF Type



AED Type



AES Type

HT Dual-Lever Nutrunners: **SAFETY** is **VITAL** in Critical Bolting

AcraDyne's Nutrunners are designed with ultimate operator safety in mind. The optional dual-lever design helps prevent:



! Injuries from Accidental Tool Start

Two-hand operation with no tie-down feature requires the operator to use both hands on the trigger simultaneously. This eliminates the possibility of accidental tool start and keeps both of the operator's hands out of harm's way.

! Strain Caused by Awkward Tool Operation

Multiple handle styles ensure the safest, most ergonomic tool for your specific application.

! Hand and Finger Trauma

Significantly reduce the risk of crushed or mutilated fingers from unintended tool start.

Protect your most valuable asset – your tool operator.

AcraDyne High Torque DC Dual-Lever Tools



HT Fixed Gearcase Dual-Lever Tools

Dual Lever Model	Approx. Torque		Approx. Speed RPM	Weight		Length (incl sq. dr)		Dia.		Drive IN	Sound Level dB(A)
	NM	FT-LB		KG	LB	MM	IN	MM	IN		
HT Series Fixed Gearcase: Dual-Lever Models For Straight Type Tools Only: (L) = Left-Side Handle (R) = Right-Side Handle											
6000 Series											
AE(P)(F)4A66250BDL AE(S)4A66250BDL(L)(R)	250	185	315	3.9	9	P = 314 12.4 F = 331 13 S = 440 17.3	67.3	2.7		0.75	66
AE(P)(F)4A66425BDL AE(S)4A66425BDL(L)(R)	425	315	165	3.9	9					0.75	66
AE(P)(F)4A66625BDL AE(S)4A66625BDL(L)(R)	625	460	106	4.1	9					0.75	66
AE(P)(F)4A66925BDL AE(S)4A66925BDL(L)(R)	925	682	72	4.1	9					0.75	66
7000 Series											
AE(P)(F)4A771000BDL AE(S)4A771000BDL(L)(R)	1,000	738	65	5.9	13	P = 324 12.7 F = 343 13.5 S = 453 17.8	77.5	3.1	1	66	
AE(P)(F)4A772500BDL AE(S)4A772500BDL(L)(R)	2,500	1,844	25	6.8	15	P = 359 14.1 F = 379 14.9 S = 488 19.2	77.5	3.1	1	66	
8000 Series											
AE(F)4A884200B1DL AE(F)4A884200BDL	4,200	3,100	12	10.4	23	410 16.1	91.2	3.6	B1 = 1 B = 1.5	66	
AE(F)4A885000BDL	5,000	3,700	9.3	10.4	23	410 16.1	91.2	3.6	1	66	
AE(P)(F)4A896500BDL	6,500	4,800	7	15.0	33	P = 438 17.2 F = 462 18.2	102.4	4	1.5	66	
AE(F)(J)4A898100BDL*	8,100	6,000	5	15.0	33	F = 462 18.2 J = 462 18.2	102.4	4	1.5	66	

* 8,100 Nm - 17,000 Nm models are not supported by the Gen III controller platform. The Gen IV controller platform is required.

HT 360° Swivel Gearcase Dual-Lever Tools

Dual Lever Model	Approx. Torque		Approx. Speed RPM	Weight		Length (incl sq. dr)		Dia.		Drive IN	Sound Level dB(A)
	NM	FT-LB		KG	LB	MM	IN	MM	IN		
HT Series 360° Swivel Gearcase: Dual-Lever Models For Straight Type Tools Only: (L) = Left-Side Handle (R) = Right-Side Handle											
6000 Series											
AE(P)(F)4B66250BDL AE(S)4B66250BDL(L)(R)	250	185	315	4.6	10.5	P = 353 13.9 F = 369 14.5 S = 630 24.8	67.3	2.7	0.75		66
AE(F)4B66425BDL AE(S)4B66425BDL(L)(R)	425	315	165	4.6	10.5					66	
AE(F)4B66625BDL AE(S)4B66625BDL(L)(R)	625	460	106	4.8	10.5					66	
AE(F)4B66925BDL AE(S)4B66925BDL(L)(R)	925	682	72	4.8	10.5					66	
7000 Series											
AE(P)(F)4B771000BDL AE(D)4B771000BDL(L) AE(S)4B771000BDL(L)(R)	1,000	738	65	6.6	14.5	P = 361 14.2 F = 343 13.5 D = 438 17.2 S = 492 19.4	77.5	3.1	1	66	
AE(D)4B771800BDL(L)	1,800	1,328	28	7.5	16.5	475 18.7	77.5	3.1	1	66	
AE(P)(F)4B772500BDL AE(D)4B772500BDL(L) AE(S)4B772500BDL(L)(R)	2,500	1,844	25	7.5	16.5	P = 398 15.7 F = 379 14.9 D = 475 18.7 S = 528 20.8	77.5	3.1	1	66	
8000 Series											
AE(P)(F)4B896500BDL	6,500	4,800	5	16.4	36	P = 475 18.7 F = 499 19.7	104	4.1	1.5	66	
AE(J)4B898100BDL*	8,100	6,000	5	16.4	36	499 19.7	104	4.1	1.5	66	

* 8,100 Nm - 17,000 Nm models are not supported by the Gen III controller platform. The Gen IV controller platform is required.

AIMCO can provide customized tooling solutions for even the most unique applications. Let us propose a solution tailored to your needs. Contact an AIMCO Customer Service Associate for more details, 1-503-254-6600, or toll free 1-800-852-1368.

AcraDyne HTXD Extreme Duty High Torque Tools

AcraDyne® HTXD

**EXTREME
DUTY**

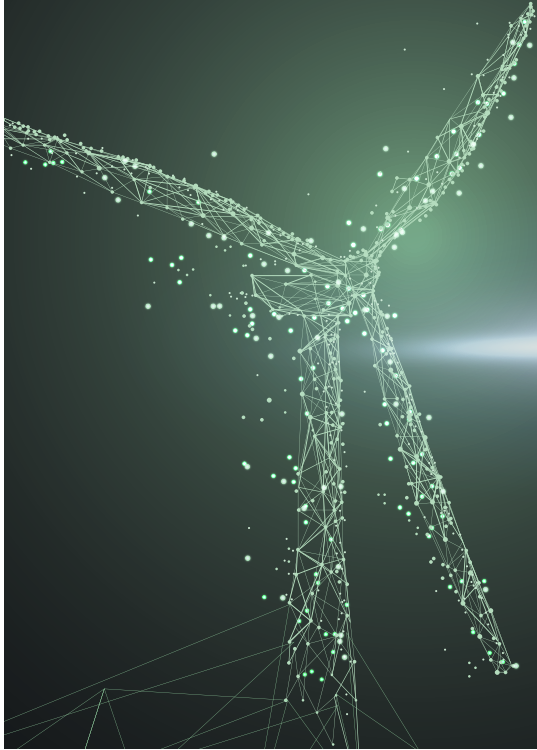

Full-Strength Tools for Big Jobs

AcraDyne's HTXD Nutrunner/Gen IV Controller System is one of the Most Accurate High-Torque Bolting Systems in the World



17,000 Nm Tool
U.S. Patent D968491

- Measures traceable, dynamic torque directly at the square drive, and the built-in transducer ensures accurate torque values. The torque reported is the torque delivered
- Available in J handle and Pistol handle configurations
- Extreme Duty engineering with motors rated for bolting applications near continuous duty
- Patented dual J-Handle models have additional safety features: Operators must use both hands on the trigger simultaneously, eliminating the possibility of accidental tool start and keeping both of the operator's hands out of harm's way
- Wide range of tightening strategies available including Torque Control, Torque plus Angle, Angle Control, and Yield Control

AcraDyne HTXD Extreme Duty High Torque Tools

AcraDyne® HTXD **EXTREME DUTY**

AcraDyne's HTXD Systems measure traceable, dynamic torque directly at the square drive and the built-in transducer ensures accurate torque values.

- Accuracy and traceability are assured from the first fastening to the last
- Torque reported is the torque delivered
- Accuracy not affected by gearing efficiency

Tools with the gearing after the transducer cannot claim this!



Pistol Model
12,000 Nm



J-Handle Model
12,000 Nm



Fixtured Model
6,500 Nm



12,000 Nm

Dual J-Handle Models



17,000 Nm
U.S. Patent D968491

HT 360° Swivel Gearcase Bolting Tools for Extreme Duty

Model	Series	Approx. Torque		Approx. Speed RPM	Weight *		Length (incl sq. dr)		Dia.		Drive IN	Sound Level dB(A)
		NM	FT-LB		KG	LB	MM	IN	MM	IN		
AEJ = J Handle/Axial Type AEP = Pistol Type AEF = Fixtured Type Single-Handle Models Standard. Add "DL" to Model Numbers for Dual Handles (AEJ models only)												
Fixed Gearcase												
AEF4A996500B	9000	6,500	4,800	5.8	19	42	494	19.5	104	4.1	1.5	66
360° Swivel Gearcase												
AEP4W998100B	9000	8,100	6,000	2.3	21.8	48	544	21.4	104	4.1	1.5	66
AEJ4W998100B	9000	8,100	6,000	2.3	21.8	48	544	21.4	104	4.1	1.5	66
AEJ4U998100BDL	9000	8,100	6,000	2.3	21.8	48	427	16.8	104	4.1	1.5	66
AEP4W9X12000B	9X	12,000	8,850	2	31.8	70	572	22.5	131	5.2	1.5	66
AEJ4W9X12000B	9X	12,000	8,850	2	31.8	70	572	22.5	131	5.2	1.5	66
AEJ4U9X12000BDL	9X	12,000	8,850	2	31.8	70	441	17.4	131	5.2	1.5	66
AEP4W9Y17000B	9Y	17,000	12,500	1	42.6	94	381	15	153	6.0	2.5	66
AEJ4W9Y17000B	9Y	17,000	12,500	1	42.6	94	381	15	153	6.0	2.5	66
AEJ4U9Y17000BDL	9Y	17,000	12,500	1	42.6	94	458	18	153	6.0	2.5	66

* Weight is tool only w/o Socket and Reaction Bar

AcraDyne HTXD Extreme Duty High Torque Tools



EXTREME DUTY

Ultimate Operator Safety for Lifting Larger Bolting Tools

AcraDyne's XD Lift Assist device for tool suspension and use allows for easy handling of equipment that otherwise would need two operators to position.

FEATURES AND BENEFITS

- Lift can be assembled/disassembled in less than 15 minutes
- Can be used inside wind turbines at deck platforms
- Designed for a wide variety of applications including narrow tower platforms and ladder spaces
- Lift Assist weighs 30 kg / 67 lbs
- Weight of unit is below the weight allowed to be lifted by personnel inside or outside the tower
- Disassembled Lift Assist is transported in a load-rated bag that can be lifted manually or by hoist within the tower
- Device is rated for loads up to 200 kg / 440 lbs
- Full-swivel wheels with locking brakes make movement and repositioning easy

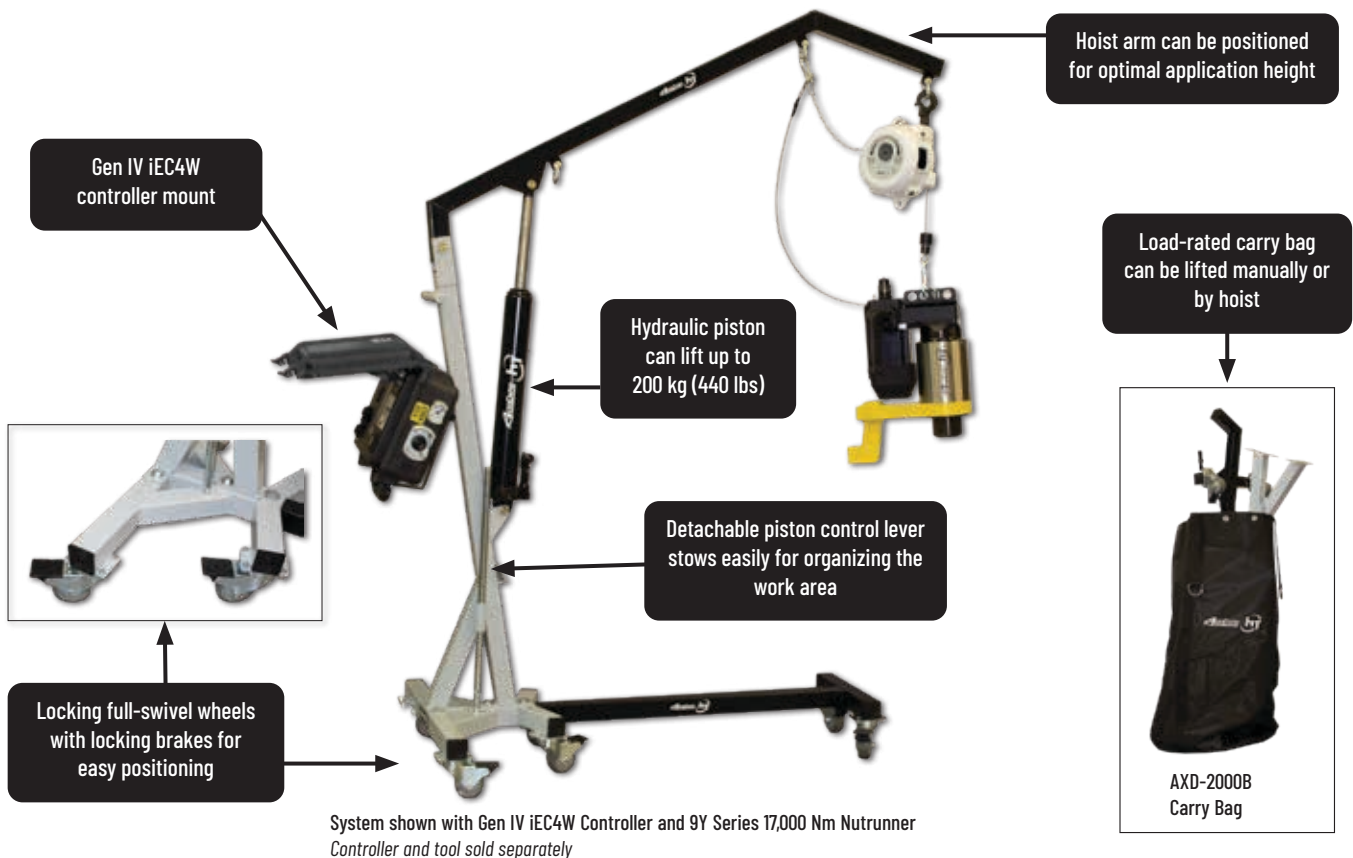

AcraDyne Gen IV Field Controller

Improved design of AcraDyne's powerful Gen IV Field Controller means increased durability, lighter weight, and quick and easy setup



iEC4WF Field Controller



Rugged, Lightweight Case

FEATURES AND BENEFITS

- Optimized for extreme duty applications >5,000 Nm
- The Gen IV Controller utilizes three tightening strategies:
 - Torque Control: Drive the tool to a pre-set Target Torque
 - Angle Control: Drive the tool to or measure a pre-set Degree of Angle
 - Yield Control: Drive the tool to the Fastener Yield Point to achieve maximum clamp load
- Multiple fastening strategies – Program up to 256 parameters with as many as 20 steps
- Jobs capability – 99
- Real-time curve viewing. Curve storage – 20,000
- Rundown storage – 1,000,000
- Event log – 5,000
- Backup & restore through USB
- Weatherproof, rugged case protects from the toughest environments
- Compact design weighs less than 20 lbs
- Ground clamp is quick and easy to set up and eliminates additional parts that are substantially heavy
- Optional tool fan kit helps prevents tool overheating
- Capable of interface with the AcraDyne series Dual-Lever tools that offer two-hand, no tie down functionality
- 110V – 220V compatible
- Single Ethernet port increases speed of connectivity, signal stability, and signal consistency
- Commands any tool in the AcraDyne line from 1 Nm to 17,000 Nm, all with one cable

PERQ Advantages

PRODUCTIVITY

- Replace multiple conventional tools with one flexible controlled system
- Quick and easy setup
- Fan kit reduces downtime due to tool overheating

ERGONOMICS

- Compact, rugged case with easy carry handle makes field use easy and convenient
- Lightweight for operator comfort

RELIABILITY

- Weatherproof rugged case
- Industrial touch screen

QUALITY

- Controlled tightening and consistent torque control improves quality
- Process controls reduce human error, and ensure no missed fasteners, stripped threads, rehits, or damaged threads
- No premature shut-off

Model	Description	Dimensions W x D x H	Weight	
			LB	KG
iEC4WF	Field use controller for use with 110V or 220V service	16.1" x 12.8" x 6.9" 408 mm x 326 mm x 175 mm	18.5	8.4



NOSE EXTENSIONS

FEATURES AND BENEFITS

- Ideal for hard-to-reach applications when a torque tube, or arm, is not desirable
- A cost-effective, more flexible option compared to a multiple spindle system
- Common applications:
 - Wheel install and repair stations
 - Large flange assembly
 - Mining vehicle shovel bolts
 - Railway equipment maintenance
 - Oil and gas industry well fixtures



HT GEARHEAD TOOLS

FEATURES AND BENEFITS

- Application-specific, custom made tools fit virtually any application
- Same durable gearing as found on AcraDyne's standard HT series tools
- Model types available:
 - HT Offset Gearhead tools
 - HT Right Angle with Offset Gearhead tools
 - HT Right Angle Air tools with Offset Gearhead

Custom accessories are available for your application. Contact an AIMCO Customer Service Associate for more details, 1-503-254-6600, or toll free 1-800-852-1368.



AcraDyne High Torque Accessories

ACCESSORIES

Custom accessories are available for your application; contact an AIMCO Customer Service Associate for details, 1-503-254-6600, or toll free 1-800-852-1368.







Model	Description
26477	Swivel Bail, 6000 Series
26327	Swivel Bail, 7000 Series
25287	Swivel Bail, 8000 Series
26630	Swivel Bail, 8000/9000 Series Tools
26478	Swivel D-Handle, 6000 Series
26328	Swivel D-Handle, 7000 Series
25291	Swivel D-Handle, 8000 Series
26479	Stationary Bail, 6000 series (26336 handle not included)
26332	Stationary Bail, 7000 series (26336 handle not included)
25289	Stationary Bail, 8000 series (26336 handle not included)
26336	Fixed Handle (for use with 26479, 26332, 25289)
26337	Rear Fixed Hoist Ring, 6000/7000/8000 Series Pistols
28514	Rear Folding Hoist Ring Kit for 8000 Series Pistols
28549	Sliding Spindle, 6000 Series
27045	Sliding Spindle, 7000 Series
30300	Sliding Spindle, 8000 Series

REACTION BARS



HT tool includes a standard, spline attachment reaction device. Custom reaction devices are available. Contact an AIMCO Customer Service Associate for more details, 1-503-254-6600, or toll free 1-800-852-1368.

	Model	Description
 Single Ended Flat	26810	6000 Series
	26800	7000 Series
	25277	8000 Series
	27255	9000 Series
	30303	X Series
 Single Ended Offset	26815	2.375" Offset, 6000 Series
	26885	4.00" Offset, 6000 Series
	27200	3.10" Offset, 7000 Series
	26890	4.00" Offset, 7000 Series
	25274	3.35" Offset, 8000 Series
	25275	4.00" Offset, 8000 Series
	26840	3.35" Offset, 9000 Series
	30306	5.00" Offset, X Series
31273	5.00" Offset, Y Series	
 Double Ended Flat	26830	6000 Series
	26820	7000 Series
	25278	8000 Series
 Double Ended Offset	25276	3.35" Offset, 8000 Series

PROTECTIVE COVERS

Durable protective covers prevent marring and damage.



Model	Description
BJ10078	Protective Cover, 6000 Series
BJ10077	Protective Cover, 7000 Series
BJ10076	Protective Cover, 8000 Series

HEAVY DUTY WATER-RESISTANT CASE FOR HT TOOLS



Made of ultra high-strength polypropylene copolymer resin, this water resistant utility case protects AcraDyne HT tools.

- Molded-in hinge, trigger-release latch system, and snap-down cushion grip handle
- Resistance to UV, solvents, corrosion, and impact damage

Model	Compatible Tools	Description
CC-6000-F	6000 series	Case with molded foam insert
CC-6000-FIP	6000 series	Case with foam in place
CC-7000-F	7000 series	Case with molded foam insert
CC-7000-FIP	7000 series	Case with foam in place
CC-8000-F	8000 series	Case with molded foam insert
CC-8000-FIP	8000 series	Case with foam in place

Please contact an AIMCO Customer Service Associate for details, 1-503-254-6600, or toll free 1-800-852-1368.

DC Tools: Tool/Spindle Selection Guide

Model	RPM**	Length		Weight		Torque, Nm																						
		IN	MM	LB	KG	5	10	15	20	25	50	75	100	125	150	175	200	225	250	275	300	325	350	375	400	425	450	
Angle																												
AEN4C12004B	3,111	11.65	295.9	2.0	0.91	■																						
AEN4C12009B	1,750	11.00	279.5	2.2	1.00	■	■																					
AEN4C12014B	875	11.66	296.4	2.2	1.00	■	■	■																				
AEN4C12018B	691	11.66	296.4	2.2	1.00	■	■	■	■																			
AEN4C12022B	560	11.66	296.4	2.2	1.00	■	■	■	■	■																		
AEN32015C	1,481	14.6	371.0	2.7	1.22		■	■																				
AEN32025C	833	14.6	371.0	2.7	1.22	■	■	■	■																			
AEN32030C	803	14.4	366.2	2.8	1.27	■	■	■	■	■																		
AEN32040C	574	14.4	366.2	2.8	1.27	■	■	■	■	■	■																	
AEN33042C	1,095	16.6	422.3	4.4	2.00		■	■	■	■	■																	
AEN33053C	1,095	16.6	422.3	4.4	2.00		■	■	■	■	■	■																
AEN33060C	845	18.9	480.5	6.6	2.99			■	■	■	■	■																
AEN33090C	568	18.9	480.5	6.6	2.99			■	■	■	■	■	■															
AEN33120C	442	21.0	533.5	9.3	4.22				■	■	■	■	■	■														
AEN33200C	245	23.2	589.6	9.4	4.26					■	■	■	■	■	■													
AEN33210C	234	23.6	599.9	10.0	4.54						■	■	■	■	■	■												
AEN33300C	151	23.6	599.0	10.0	4.54							■	■	■	■	■	■	■										
AEN33375C	151	23.6	599.0	10.0	4.54								■	■	■	■	■	■	■	■								
AEN35090B	607	22.6	573.7	6.9	3.13					■	■	■	■	■														
AEN35140B	472	22.5	571.9	10.4	4.72						■	■	■	■	■													
AEN35175B	384	22.5	571.9	10.5	4.76							■	■	■	■	■												
AEN35225B	291	22.9	581.1	12.3	5.58								■	■	■	■	■											
AEN35285B	236	22.9	581.1	12.3	5.58									■	■	■	■	■	■									
AEN35350B	191	22.9	581.1	12.3	5.58										■	■	■	■	■	■								
Inline																												
AES4A12003BQ	2,625	11.12	282.7	2.0	0.91	■																						
AES4A12006BQ	2,625	11.12	282.7	2.0	0.91	■	■																					
AES4A12011BV	1,313	11.44	290.5	2.2	1.00	■	■	■																				
AES4A12014BV	1,037	11.44	290.5	2.2	1.00	■	■	■	■																			
AES4A12018BV	840	11.44	290.5	2.2	1.00	■	■	■	■	■																		
AES4A12022BV	656	11.44	290.5	2.2	1.00	■	■	■	■	■	■																	
AES32010CV	2,222	13.9	351.7	2.5	1.13	■	■																					
AES32020CV	1,250	13.9	351.7	2.5	1.13	■	■	■																				
AES32025CV	893	13.9	351.7	3.2	1.45	■	■	■	■																			
AES32038CV	595	16.7	424.0	4.2	1.91		■	■	■	■																		
AES33040CV	1,314	18.2	463.4	6.4	2.90			■	■	■	■																	
AES33060CV	883	18.2	463.4	6.4	2.90			■	■	■	■	■																
AES33100CV	489	22.6	573.0	8.1	3.67				■	■	■	■	■															
AES33150CV	329	22.6	573.0	8.1	3.67					■	■	■	■	■														
AES33230CV	221	22.6	573.0	8.1	3.67						■	■	■	■	■													
AES33230C-2	221	22.6	573.0	8.1	3.67							■	■	■	■	■												
AES33400CV	122	24.9	632.5	13.0*	5.90*								■	■	■	■	■	■	■	■								
AES33600CV**	82	24.9	632.5	13.0*	5.90*									■	■	■	■	■	■	■	■	■	■	■	■	■	■	■
AES35075AV	944	21.9	555.2	9.2	4.17					■	■	■	■															
AES35090AV	767	21.9	555.2	9.2	4.17					■	■	■	■	■														
AES35110AV	634	21.9	555.2	9.2	4.17						■	■	■	■	■													
AES35135AV	515	21.9	555.2	9.2	4.17							■	■	■	■	■												
AES35170AV	418	21.9	555.2	9.2	4.17								■	■	■	■	■											
AES35280A	236	24.2	615.1	12.8	5.81									■	■	■	■	■	■	■								
AES35350A	192	24.2	615.1	12.8	5.81										■	■	■	■	■	■	■	■	■	■	■	■	■	■
AES35420A	159	24.2	615.1	12.8	5.81											■	■	■	■	■	■	■	■	■	■	■	■	■
AES35515A***	129	24.2	615.1	12.8	5.81												■	■	■	■	■	■	■	■	■	■	■	■
AES35635A****	104	24.2	615.1	12.8	5.81													■	■	■	■	■	■	■	■	■	■	■

* Includes reaction bar and fixture nut.
 ** Torque Range: 120-480 Nm Max Torque: 600 Nm
 *** Torque Range: 128-515 Nm
 **** Torque Range: 159-635 Nm

Recommended Torque Range

Continued on next page



DC Tools: Tool/Spindle Selection Guide

Model	RPM**	Length		Weight		Torque, Nm																							
		IN	MM	LB	KG	5	10	15	20	25	50	75	100	125	150	175	200	225	250	275	300	325	350	375	400	425	450		
Pistol																													
AEP4_12003B_	2,625	7.3	186.3	2.2	1.00	█																							
AEP4_12006B_	2,625	7.3	186.3	2.2	1.00	█	█																						
AEP4_12011BV	1,313	8.0	203.3	2.3	1.04	█	█	█																					
AEP4_12014BV	1,037	8.0	203.3	2.3	1.04	█	█	█	█																				
AEP4_12018BV	840	8.0	203.3	2.3	1.04	█	█	█	█	█																			
AEP4_12022BV	656	8.0	203.3	2.3	1.04	█	█	█	█	█	█																		
AEP4_22020BV	1,313	8.7	219.9	2.4	1.09	█	█	█	█	█	█																		
AEP4_22025BV	1,037	8.7	219.9	2.4	1.09	█	█	█	█	█	█	█																	
AEP4_22030BV	840	8.7	219.9	2.4	1.09	█	█	█	█	█	█	█	█																
AEP4_22035BV	747	8.7	219.9	2.4	1.09	█	█	█	█	█	█	█	█	█															
AEP4_22040BV	656	8.7	219.9	2.4	1.09	█	█	█	█	█	█	█	█	█	█														
AEP35075AV	944	16.0	405.2	9.2	4.17																								
AEP35090AV	767	16.0	405.2	9.2	4.17																								
AEP35110AV	634	16.0	405.2	9.2	4.17																								
AEP35135AV	515	16.0	405.2	9.2	4.17																								
AEP35170AV	418	16.0	405.2	9.2	4.17																								
AEP35280A	236	18.4	468.2	13.6	6.17																								
AEP35350A	192	18.4	468.2	13.6	6.17																								
AEP35420A	159	18.4	468.2	13.6	6.17																								
AEP35515A*	129	18.4	468.2	13.6	6.17																								
AEP35635A**	104	18.4	468.2	13.6	6.17																								
Tubenut																													
AET4A12018B	516	15.41	288.1	3.1	1.41	█	█																						
AET4A12025B	387	15.41	288.1	3.1	1.41	█	█	█																					
AET4A12025B-KD	387	15.9	404.9	3.1	1.41	█	█	█	█																				
AET32020C	622	17.2	436.4	3.1	1.41	█	█	█	█																				
AET32025C	466	17.8	450.9	4.0	1.81	█	█	█	█	█																			
AET32035C	347	18.1	460.5	4.5	2.04	█	█	█	█	█	█																		
AET32050C	257	18.8	478.0	5.6	2.54	█	█	█	█	█	█	█																	

* Torque Range: 128 - 515 Nm
 ** Torque Range: 159 - 635 Nm

Recommended Torque Range



High Torque Series

Model Number Ending In	RPM**	Length		Weight		Torque, Nm																								
		IN	MM	LB	KG	50	100	200	300	400	500	600	850	1100	1200	1300	1500	2000	2500	3000	4000	5000	6500	8100	12000	17000				
66250B (DL)	315	12.4 - 24.8	314 - 630	9 - 12	3.9 - 5.3	█	█																							
66425B (DL)	165	12.4 - 24.8	314 - 630	9 - 12	3.9 - 5.3	█	█	█																						
66625B (DL)	106	12.4 - 24.8	314 - 630	9 - 12	4.1 - 5.5	█	█	█	█																					
66825B (DL)	72	12.4 - 24.8	314 - 630	9 - 12	4.1 - 5.5	█	█	█	█	█																				
771000B (DL)	65	12.7 - 19.4	324 - 492	13 - 16	5.9 - 7.3	█	█	█	█	█	█																			
771800BDL	28	18.7	475	7.5	16.5	█	█	█	█	█	█	█																		
772500B (DL)	25	14.1 - 20.8	359 - 528	15 - 18	6.8 - 8.2	█	█	█	█	█	█	█	█																	
872800B	9	16 - 17	406 - 430	22	10	█	█	█	█	█	█	█	█	█																
884200B1 (DL)	12	410 - 446	16.1 - 17.6	23 - 26	10.4 - 11.8	█	█	█	█	█	█	█	█	█	█															
884200B (DL)	12	410 - 446	16.1 - 17.6	24.5	11.1	█	█	█	█	█	█	█	█	█	█	█														
885000B1	4.5	16.6 - 17.6	422 - 446	26	11.8	█	█	█	█	█	█	█	█	█	█	█														
885000B	4.5	16.6 - 17.6	422 - 446	26	11.8	█	█	█	█	█	█	█	█	█	█	█	█													
885000BDL	9.3	16.1	410	23	10.4	█	█	█	█	█	█	█	█	█	█	█	█													
896500B (DL)	5 - 7	17.2 - 19.7	438 - 499	33 - 36	15 - 16.4	█	█	█	█	█	█	█	█	█	█	█	█	█												
898100B (DL)	5	18.2 - 20.9	462 - 532	33 - 36	15 - 16.4	█	█	█	█	█	█	█	█	█	█	█	█	█	█											
996500B	5.8	19.5	494	42	19	█	█	█	█	█	█	█	█	█	█	█	█	█	█	█										
998100B (DL)	2.3	21.4	544	48	21.8	█	█	█	█	█	█	█	█	█	█	█	█	█	█	█	█									
9X12000B (DL)	2	17.4 - 22.5	441 - 572	70	31.8	█	█	█	█	█	█	█	█	█	█	█	█	█	█	█	█	█								
9Y17000B (DL)	1	15 - 18	381 - 458	94	42.6	█	█	█	█	█	█	█	█	█	█	█	█	█	█	█	█	█	█							

Recommended Torque Range

AcraDyne Accessories

CABLE ASSEMBLIES

The AcraDyne DC electric nutrunner tool system uses a single cable to carry all necessary conductors for superior ergonomics and durability.

- Flexible polyurethane cover for maximum durability, abrasion and transmission fluid resistant
- Quick disconnects at both ends facilitate tool changeover and troubleshooting
- The CAN data/signal is via RJ45 for products such as the KDM socket tray or computer

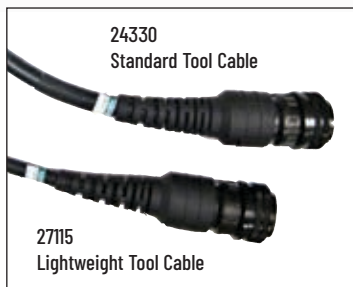

Model	Description	Length	
		M	Ft
Tool Cables			
24330	G3/G4 Tool Cable 3M	3	9.8
25350	G3/G4 Tool Cable 5M	5	16.4
24320	G3/G4 Tool Cable 10M	10	32.8
27110	G3/G4 Tool Cable 3M Lightweight*	3	9.8
27115	G3/G4 Tool Cable 5M Lightweight*	5	16.4
27122	G3/G4 Tool Cable 10M Lightweight*	10	32.8
Extensions			
24320	Extension cable 10M	10	32.8
25518	Extension cable 20M	20	65.6

*Lightweight cables are for use only with 1000 & 2000 Series tools.

CABLE ADAPTERS AND CONNECTORS

	Model	Description
Adapters and Connectors		
	26364	G3/G4 Right Angle Cable Adapter
	25491	G3/G4 Breakaway Cable Connector - Ensures disconnect of cable should stress in excess of 40 lbs. occur (see below)
	30355	Y Cable Harness connects G4 iAC controller and controller's I/O to tool's EC/ MCCBL cable. Compatible with UA-40S(D) MC, UA-50S(D)MC, UA-60S(D)MC, UA-70SMC, and UA-150MC tools.

DATA INTERFACE OPTION

	Model	Description
Data Interface Options		
	27348	I/O Wiring Connector - Simple module to facilitate connections to I/O on iEC Controllers
	28292	System Port Cable, USB 2.0 Cable, A Male to B Male, 3M

BREAKAWAY CABLE CONNECTOR

Innovative Quick Disconnect Device reduces cable damage from dropping tools or pulling cables when in use.

- Easily snaps into place, using magnetic force, at either the tool or the controller
- Adjust holding force by removing or adding magnets. Max holding force is 40 lbs / 18 kg

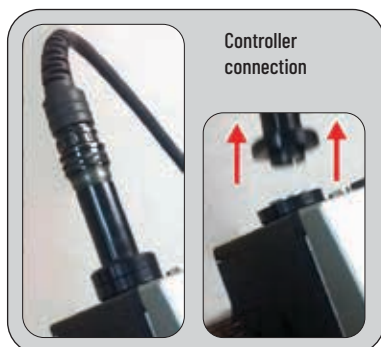

LIGHT TOWER



Cost- and energy-efficient LED light tower is visible from any direction, angle, and distance

- Two built-in alarms (FB Type) with selectable sound patterns
- Adjustable Volume (Max. 85 dB at 1 m)
- Tower includes red, yellow, green, blue, and clear lenses



AcraDyne Accessories

FRL ASSEMBLY KIT

For use with the iAC controller, AcraDyne's FRL assembly kit includes a regulator and solenoid. The kit attaches to the controller or can operate as a stand-alone unit.



Top view



30850 FRL Assembly Kit

ANGLE TOOL BODY JACKETS

Keep tools protected with AIMCO's tool Body Jackets.



Model	Description
BJ10051	For 1000 series angle tools
BJ10052	For 2015, 2025 series angle tools
BJ10053	For 2030, 2040, 2055 series angle tools
BJ10054	For 3060, 3090 series angle tools
BJ10055	For 3120, 3200 series angle tools

SOCKET TRAYS

Socket trays, for use with iEC and UEC Controllers, are supplied with blank socket pucks machined to fit specific sockets for the application. AIMCO provides this machining as an additional service. When ordering, please specify the outer dimensions of the sockets you plan to use, and whether you would like a quote for the machining service.

- Simply remove the assigned socket to select the application to be run
- Quick and easy set up. Parameters assigned to socket position automatically
- Optional self-illuminating socket receptacles
- Delrin® blanks may be easily machined by the customer to accommodate custom socket profiling
- Nothing to break, wear out, or maintain
- Proximity sensors detect presence of socket



Model	Description
AMPST-2-I	2-Position Socket Tray for iEC Controllers, 2 x 1, 1.25" Socket
AMPST-2-U	2-Position Socket Tray for UEC Controllers, 2 x 1, 1.25" Socket
AMPST-4-I	4-Position Socket Tray for iEC Controllers, 2 x 2, 1.25" Socket
AMPST-4-U	4-Position Socket Tray for UEC Controllers, 2 x 2, 1.25" Socket
AMPST-6S-I	6-Position Socket Tray for iEC Controllers, 6 x 1, 1.25" Socket
AMPST-6S-U	6-Position Socket Tray for UEC Controllers, 6 x 1, 1.25" Socket
AMPST-6-I	6-Position Socket Tray for iEC Controllers, 3 x 2, 1.25" Socket
AMPST-6-U	6-Position Socket Tray for UEC Controllers, 3 x 2, 1.25" Socket
AMPST-8-I	8-Position Socket Tray for iEC Controllers, 4 x 2, 1.25" Socket
AMPST-8-IL	8-Position Socket Tray for iEC Controllers, 4 x 2, 2.0" Socket
AMPST-8-U	8-Position Socket Tray for UEC Controllers, 4 x 2, 1.25" Socket

Socket trays with 6 - 8 positions are available in varied configurations to suit workspace requirements (straight or double rows). Tell your AIMCO representative your specific requirements when inquiring.

BAR CODE SCANNER

Sturdy bar code scanners allow you to easily scan small, stacked, or poorly printed, one-dimensional bar codes. Kit includes a cradle, power supply, and USB/Ethernet cable.



28859
Bluetooth®-Enabled
Scanner Kit

- Scratch proof, tempered glass exit window
- Single-circuit board construction eliminates common interconnection failures
- Industrial long-life charging contacts can withstand 250,000+ insertions into cradle
- Wireless scanner enables users to hold scanner at any angle

Model	Description
20400	RS232 Barcode Reader Kit
28859	RS232 Wireless Barcode Reader Kit

AcraDyne Accessories

CONTROLLER BRACKETS

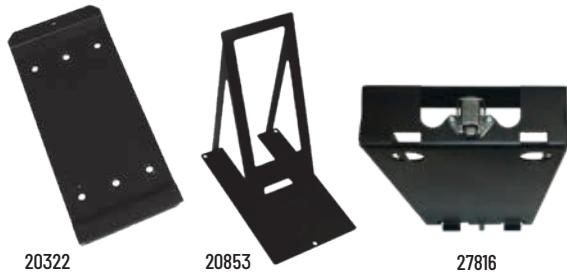

Model	Description
20322	Basic wall-mounting plate
20853	Table stand free standing platform
27816	Mounting bracket with internal wireways

TOOL BAILS

- AcraDyne's spring bails are designed for use with any of the AcraDyne 1000, 2000, or 3000 Series tools
- Spring bails snap on quickly and firmly at any place on the body of the tool for perfect balance and secure suspension

Model	Description
 25501	Wire Bail for 1000 Series Tools
 27594	Stationary Bail for 1000 Series Tools
 27791	Rotating Bail Assembly for 1000 Series Tools
 26568	Cable Bail to Hang Tool Vertically for Gen III Cables
 21208	Spring Bail for 2000 Series Tools
 23662	Rotating Bail for 2000 Series Tools
 28475	Rotating Bail for AEN33042C and AEN33053C
 23575	Rotating Bail for 3000 Series Tools

MOUNTING BRACKETS

Model	Description
 25717	Mounting Bracket for 1000 Series Angle Tools
 25843	Mounting Bracket for 1000 Series Push-To-Start Tools
 26443	Mounting Bracket for 1000/2000 Series Straight and Pistol Tools
 24824	Mounting Flange for 1000/2000 Series Straight and Pistol Tools
 28622	Mounting Flange for 2000 Series Inline Tools
 30340	Mounting Bracket for 2000 Series Angle Tools
 30351	Mounting Bracket, Drive End for 2000 Series Inline Tools
 25718	Mounting Bracket for 3000/5000 Series Angle Tools
 26570	Mounting Bracket for 3000/5000 Series Straight Tools
 25265	Angle head Mounting Bracket (Cradle type) for 3000/5000 Angle Tools over 225 Nm
 26394	Mounting Flange for 5000 Series

TOOL STORAGE

Tool baskets and tool hangers are a great way to keep a tool in place when not being used.

UNIVERSAL TOOL BASKET

Interchangeable among angle head and pistol grip tool models throughout the industry.



VERTICAL TOOL HANGER

Designed for AcraDyne Gen 1/Gen 2 tools.

AcraDyne Cordless AB Series

AcraDyne Cordless AB Series INNOVATIVE TOOLS IN A POWERFUL PACKAGE

AcraDyne's high-performance cordless tools deliver precise torque and/or angle to the fastener. Innovative technology guarantees repeatable torque results every time, ensuring you meet your most important goal – creating quality products. The tools are available in two model types:

1 **AB-MTA**
Clutch
Shut-Off
Tool

*Measures
Torque and
Reports Angle*

2 **AB-CTA**
Transducer
Shut-Off
Tool

*Controls Torque
and Angle*



FEATURES AND BENEFITS OF ALL AB TOOLS

- Self-Controlling Tools
Can run stand alone or in conjunction with an iBC ACE Platform controller as a line interface (see page 9)
- Tool programming done with no-cost AcraDyne Tool Manager software using USB cable interface to PC
- Selectable vibration alarm provides tactile feedback
- 99 programs with 6 steps per program available
- Job functionality for sequencing and/or bolt counting
- Programmable
 - Torque
 - Angle
 - RPM
 - Time
 - Fastening direction
- Multicolor LED status screen
- 150,000 results stored on-board

TORQUE RANGES

AB-MTA

- Pistol Tool: 1.0 – 17 Nm
- Straight Tool: 1.0 – 17 Nm
- Angle Tool: 2.5 – 115 Nm

AB-CTA

- Pistol Tool: 1.5 – 3,000 Nm (torque range for pistol tools includes Ultra Torque models on page 51)
- Straight Tool: 1.5 – 17 Nm
- Angle Tool: 1.5 – 120 Nm
- Tubenut Tool: 3.0 – 20 Nm

AcraDyne Cordless AB Series



MTA Series

Measures Torque and Reports Angle

The AB-MTA Series controls torque to the fastener with a precision Clutch Shut-Off mechanism. This technology increases productivity by allowing the tool to run at higher speeds and with minimal overshoot. The highly accurate clutch reduces torque reaction transmitted to the operator through its speed of shut-off at the moment reaction forces are generated.



For simple adjustment, the MTA series provides easy clutch access.



AcraDyne Cordless AB-MTA Series Tools

Model	Torque Range		Max Speed RPM	Drive Type	Weight W/O Battery		Tool Dimensions							
	NM	FT-LB			KG	LB	A		B		C		D	
							IN	MM	IN	MM	IN	MM	IN	MM
Pistol														
ABP-MTA06(Q)(WQ)(BQ)(WBQ)	1.0 - 6	0.8 - 4.4	1,100	1/4" QC	1.25	2.75	9.1	230	1.02	26	8.56	218	4.5	115
ABP-MTA08(Q)(WQ)(BQ)(WBQ)	1.5 - 8	1.1 - 5.9	880	1/4" QC	1.25	2.75	9.1	230	1.02	26	8.56	218	4.5	115
ABP-MTA12(Q)(WQ)(BQ)(WBQ)	2.3 - 12	1.7 - 8.9	629	1/4" QC	1.25	2.75	9.1	230	1.02	26	8.56	218	4.5	115
ABP-MTA17(Q)(WQ)(BQ)(WBQ)	3.5 - 17	2.6 - 12.5	449	1/4" QC	1.25	2.75	9.1	230	1.02	26	8.56	218	4.5	115
Straight														
ABS-MTA06(Q)(WQ)(BQ)(WBQ)	1.0 - 6	0.8 - 4.4	1,100	1/4" QC	1.0	2.2	17.2	437	3.19	81	0.79	20	4.5	115
ABS-MTA08(Q)(WQ)(BQ)(WBQ)	1.5 - 8	1.1 - 5.9	880	1/4" QC	1.0	2.2	17.2	437	3.19	81	0.79	20	4.5	115
ABS-MTA12(Q)(WQ)(BQ)(WBQ)	2.3 - 12	1.7 - 8.9	629	1/4" QC	1.1	2.4	17.2	437	3.19	81	0.79	20	4.5	115
ABS-MTA17(Q)(WQ)(BQ)(WBQ)	3.5 - 17	2.6 - 12.5	449	1/4" QC	1.25	2.75	17.2	437	3.2	81	0.8	20	4.5	115
Angle														
ABN-MTA10(W)(B)(WB)	2.5 - 10	1.9 - 7.4	629	3/8" Sq.	1.35	3.0	17.9	455	3.94	100	1.12	29	4.5	115
ABN-MTA17(W)(B)(WB)	3.5 - 17	2.6 - 12.5	420	3/8" Sq.	1.4	3.1	18.1	461	4.14	105	1.29	33	4.5	115
ABN-MTA24(W)(B)(WB)	5 - 24	3.7 - 17.7	300	3/8" Sq.	1.4	3.1	18.1	461	4.14	105	1.29	33	4.5	115
ABN-MTA55(W)(B)(WB)	13 - 55	9.6 - 40.6	94	3/8" Sq.	2.7	6.0	22.5	572	7.7	196	1.65	42	4.5	115
ABN-MTA90(W)(B)(WB)	9.6 - 90	13.3 - 66.4	70	3/8" Sq.	2.9	6.4	25.9	658	10.2	259	1.8	46	4.5	115
ABN-MTA115(W)(B)(WB)	23 - 115	17 - 84.8	56	1/2" Sq.	3.1	6.8	28.4	721	13.9	353	2.8	71	4.5	115

W = WiFi option B = Barcode option Q = Quick Change

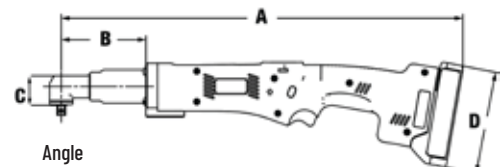
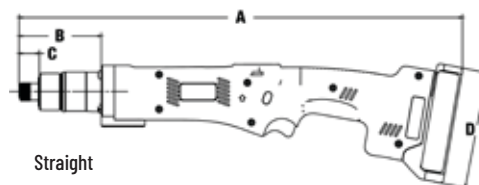
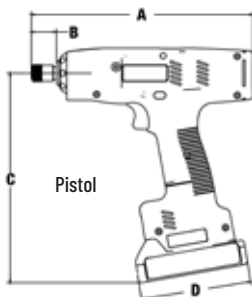

AcraDyne Cordless AB Series



CTA Series

Controls Torque and Angle

The AB-CTA Series provides the most sophisticated option in the AcraDyne cordless tool line. The Transducer Shut-Off means precise torque measurement with high accuracy and traceable results. Transducer shut-off allows speed adjustment and provides the ability to reject conditions such as cross threads and double hits on a fastener.



AcraDyne Cordless AB-CTA Series Tools

Model	Torque Range		Max Speed RPM	Drive TYPE	Weight W/O Battery		Tool Dimensions									
	NM	FT-LB			KG	LB	A		B		C		D		E	
							IN	MM	IN	MM	IN	MM	IN	MM	IN	MM
Pistol																
ABP-CTA12(O)(WQ)(BQ)(WBQ)	1.5 - 12	1.1 - 8.9	629	1/4" QC	1.15	2.5	9.1	230	1.02	26	8.56	218	4.5	115	-	-
ABP-CTA17(O)(WQ)(BQ)(WBQ)	3 - 17	2.2 - 12.5	449	1/4" QC	1.15	2.5	9.1	230	1.02	26	8.56	218	4.5	115	-	-
For 120 – 5,000 Nm Pistol Tools, see Ultra Torque models on page 51																
Straight																
ABS-CTA12(O)(WQ)(BQ)(WBQ)	1.5 - 12	1.1 - 8.9	570	1/4" QC	0.95	2.1	17.2	437	3.19	81	0.79	20	4.5	115	-	-
ABS-CTA17(O)(WQ)(BQ)(WBQ)	3 - 17	2.2 - 12.5	460	1/4" QC	0.95	2.1	17.2	437	3.19	81	0.79	20	4.5	115	-	-
Angle																
ABN-CTA10(W)(B)(WB)	1.5 - 10	1.1 - 7.4	570	3/8" Sq.	1.35	3.0	17.9	455	3.94	100	1.12	29	4.5	115	-	-
ABN-CTA17(W)(B)(WB)	2.5 - 17	1.8 - 12.5	380	3/8" Sq.	1.4	3.1	18.1	461	4.14	105	1.29	33	4.5	115	-	-
ABN-CTA24(W)(B)(WB)	5 - 24	3.7 - 17.7	300	3/8" Sq.	1.2	2.6	18.1	461	4.14	105	1.29	33	4.5	115	-	-
ABN-CTA36(W)(B)(WB)	8 - 36	5.9 - 26.6	170	3/8" Sq.	1.2	2.6	21.6	547	7	179	1.65	42	4.5	115	-	-
ABN-CTA55(W)(B)(WB)	15 - 55	11.1 - 40.6	90	3/8" Sq.	1.4	3.1	23.1	587	8.61	219	1.65	42	4.5	115	-	-
ABN-CTA90(W)(B)(WB)	25 - 90	18.4 - 66.6	60	1/2" Sq.	2.9	6.4	25.9	658	11.4	290	1.91	49	4.5	115	-	-
ABN-CTA120(W)(B)(WB)	35 - 120	25.8 - 88.5	50	1/2" Sq.	3.1	6.8	28.4	720	13.9	352	2.81	71	4.5	115	-	-
Tubenut																
ABT-CTA15W	3 - 15	2.2 - 11.1	400	1/4" - 7/16" hex	1.2	2.6	22.2	565	7.82	199	4.17	106	4.5	115	0.5	12.7
ABT-CTA24W	6 - 24	4.4 - 17.7	300	3/8" - 5/8" hex.	1.2	2.6	22.9	582	8.39	213	4.74	121	4.5	115	0.56	14

W = WiFi option B = Barcode option Q = Quick Change

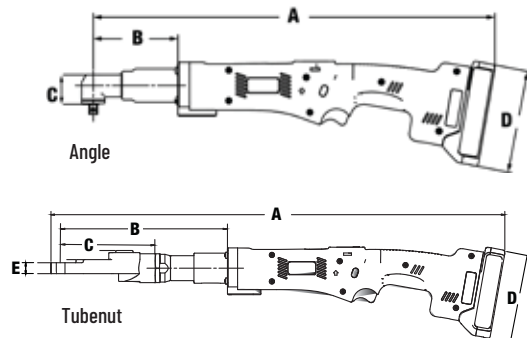
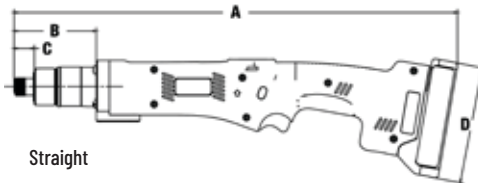
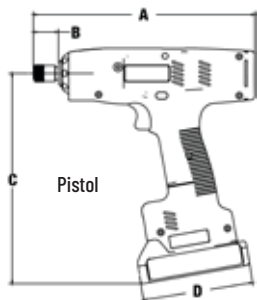

AcraDyne Cordless ABP Ultra Torque Nutrunners

Ultra Torque ABP-CTA Series

Unmatched Accuracy for Higher-Torque Applications

FEATURES AND BENEFITS

- Transducerized for precise delivery of torque and angle to the fastener
- Usable stand-alone or with AcraDyne iBC series Controller for line controls and/or data integration with QMS systems
- Sophisticated control set with AcraDyne Tool Manager program with 99 PSETS available
- Operator feedback with OLED screen, audible and tactile feedback
- Wide variety of strategies
 - Torque
 - Angle
 - Torque Plus Turn
 - Torque Minus Turn
 - And more...
- Available with Two-Hand, No Tie Down Button to ensure operator safety from accidental contact with reaction bar
- Standard Offset, Deep Offset, and Flat Reaction Bars available. Custom reaction bars available by request
- Tool supplied with one battery (P/N AB-B1850LI), see page 52 and standard reaction bar. Charger (see page 52) is purchased separately:
 - AB-C18110 (120VAC) Charger or
 - AB-C18220 (220VAC) Charger



ABP-CTA950



ABP-CTA1400W



ABP-CTA3000W



ABP-CTA3000WDL
Operator Safety: Dual Trigger Option with Two-Hand, No Tie Down Button prevents accidental contact with reaction bar

AcraDyne Cordless ABP-CTA Ultra Torque Series Tools

Model	Max Torque		Max Speed RPM	Length		Weight	Gearbox Diameter	
	NM	FT-LB		MM	IN		MM	IN
ABP-CTA120W	120	89	68	335	13.2	w/out battery: 3.7 kg / 8.04 lb w/battery: 4.3 kg / 9.44 lb	67	2.6
ABP-CTA250W	250	185	27	335	13.2	w/out battery: 3.7 kg / 8.04 lb w/battery: 4.3 kg / 9.44 lb	67	2.6
ABP-CTA450W	450	332	14	335	13.2	w/out battery: 3.7 kg / 8.04 lb w/battery: 4.3 kg / 9.44 lb	67	2.6
ABP-CTA650W	650	480	9.4	335	13.2	w/out battery: 3.7 kg / 8.04 lb w/battery: 4.3 kg / 9.44 lb	67	2.6
ABP-CTA950(W)	950	700	6.4	335	13.2	w/out battery: 3.7 kg / 8.04 lb w/battery: 4.3 kg / 9.44 lb	67	2.6
ABP-CTA1400W	1,400	1,000	4	338	13.3	w/out battery: 4.0 kg / 8.85 lb w/battery: 5.1 kg / 11.25 lb	77.5	3.1
ABP-CTA3000W	3,000	2,200	2.1	374	14.7	w/out battery: 5.6 kg / 12.31 lb w/battery: 6.2 kg / 13.71 lb	77.5	3.1
ABP-CTA5000	5,000	3,688	1.3	418	16.5	w/out battery: 7.9 kg / 17.4 lb w/battery: 8.5 / 18.8 lb	91.2	3.6

W = WiFi



AB-B1850LI Battery

AB-C18110 Battery Charger

AcraDyne Cordless Tool Accessories



Batteries & Chargers

BATTERIES

- Li-Ion for best energy density
- Deep-discharge protection prevents battery failure
- All AB models utilize the same battery connection and chargers
- Batteries available in 2.5 Ah or 5.5 Ah



AB-B1825LI



AB-B1850LI

Battery Model #	Voltage	Type	Capacity	Weight
AB-B1825LI	18V	Li-Ion	2.5 Ah	.8 Lb/.35 kg
AB-B1850LI	18V	Li-Ion	5.0 Ah	1.3 Lb/.6 kg



AB-C18110

BATTERY CHARGERS

- Battery defect detection
- Microprocessor-controlled charging: Charging time is dependent on the capacity of the battery
- Reverse polarity protection
- Automatic battery voltage detection
- Multi-bay charger includes battery adapters
- All AB models use the same batteries and chargers



AB-C18-4W

Model	Description	Output	Input	Charging Time	Dimensions (W/O Battery)	Weight
AB-C18110	Quick-charge unit for 110V	14.4V - 18V, 3.0A	110VAC, 50-60Hz	Max 55 min for 2.5 Ah battery	3.39" (W) x 4.21" (H) x 6.02" (D) 86 mm (W) x 107 mm (H) x 153 mm (D)	1.2 Lb/.55 kg
AB-C18220	Quick-charge unit for 220V	14.4V - 18V, 3.0A	220-240VAC, 50-60Hz	Max 55 min for 2.5 Ah battery	3.39" (W) x 4.21" (H) x 6.02" (D) 86 mm (W) x 107 mm (H) x 153 mm (D)	1.2 Lb/.55 kg
AB-C18-4W	4-bay charge unit for 100-240VAC	14.4V - 18V, 3.0A	100-240VAC, 50-60Hz	Max 55 min for 2.5 Ah battery	21.2" (W) x 7.2" (H) x 10.2" (D) (incl. feet) 539 mm (W) x 182 mm (H) x 260 mm (D) (incl. feet)	16.8 Lb/7.6 kg



AB-PCOLRING

COLOR INDEX RINGS

Colored rings on AB Series tools make it easy to determine tool torque with a quick glance. Set comes with four colors: blue, yellow, red, and silver.

SUSPENSION BAIL

Bails attach to tool body for perfect balance and secure suspension.



AB-PBAIL



MULTIPLE NUTRUNNING SYSTEMS

AIMCO can integrate the AcraDyne tool spindle into a customized Multiple Nutrunning system. From simple systems vertically suspended above the part, to assembly stations that integrate with your line, AIMCO can effectively accommodate your project.

LET US KNOW YOUR REQUIREMENTS AND WE WILL PROPOSE A SOLUTION TAILORED TO YOUR NEEDS.



FEATURES AND BENEFITS

- Nutrunner sequencing - Allows nutrunners to be sequenced at each phase of the tightening process, providing even distribution of torque and load to each fastener. This prevents part damage and distortion
- Snug threshold, final torque in one pass - No need for multiple torque stage sequencing. Fixtured nutrunners save time and effort
- No missed fasteners - Multiple nutrunners have a spindle dedicated to each location, ensuring quality on every rundown on every bolt
- Better residual torques - Synchronized controlled fastening allows residual torque levels to be consistent with the dynamic torque specification
- Saving in cycle time - Compared to using a single nutrunner tool with many rundowns, running all fasteners simultaneously reduces in-station cycle time
- Cost saving benefits - Saving installation cycle time frees operators to handle additional tasks and potentially reduce labor costs
- Collect data – Most common methods of collecting data for quality control and statistical analysis can be implemented from a serial data string using RS232 to formatted data from a network database

INDUSTRY APPLICATIONS

- Harvester chain-pull assembly, 2-spindle
- Engine flywheel assembly, 3-spindle
- Wheel lug nut assembly, 4-spindle
- Axle u-bolt assembly, 4-spindle
- Gasoline generator assembly, 6-spindle
- Lawn mower motor assembly, 7-spindle
- Air-cooled small vehicle engine assembly, 10-spindle

Tool Specials



AIMCO can provide customized tooling solutions for even the most unique applications. Let us propose a solution tailored to your needs. Contact an AIMCO Customer Service Associate for more details, 1-503-254-6600, or toll free 1-800-852-1368.



AcraDyne High Torque Pneumatic Tools

FEATURES AND BENEFITS

AcraDyne's High Torque Pneumatic Bolting Tools offer a reliable and dependable solution for the installation and removal of heavy-duty fasteners. Appropriate for use in industries requiring high torque capability, accuracy, power, and safety.

- Modular design allows for ease of maintenance
- Interchangeable motors and gearing
- Same proven and reliable gearbox as the AcraDyne DC line
- One-hand reverse



AAP1B66600A



AAP1B76950A



AAP1B772000A



AAP1B885100A



AAP1B Series Tools

Model	Torque		Speed (RPM)	Weight (LB)	Square Dr. (IN)	Air Consumption (CFM)
	(NM)	(FT-LB)				
AAP1B66400A	400	300	57	9.75	3/4	22.9
AAP1B66600A	600	450	39	9.75	3/4	22.9
AAP1B66850A	850	625	27	9.75	3/4	22.9
AAP1B76950A	950	700	31	10.4	3/4	26.3
AAP1B771350A	1,350	1,000	22	10.4	1	26.3
AAP1B772000A	2,000	1,475	14	12.7	1	26.3
AAP1B772950A	2,950	2,175	9	14.9	1	26.3
AAP1B885100A	5,100	3,775	8	23	1-1/2	31.5

AIR PREPARATION UNITS

Many stacking filter/regulator combinations are available. Contact an AIMCO Customer Service Associate.



AFRL-4



AFRL-4HTA Standalone Unit

28178 HT Air Tool/AFRL Carrying Kit



Maximum allowable Input Pressure not to exceed 120 PSI.

AcraDyne High Torque, High Speed Pneumatic Tools

Our High-Torque, High-Speed Pneumatic Bolting Tools offer a reliable and dependable solution for the installation and removal of heavy-duty fasteners with high torque capability, accuracy, power, and safety.

FEATURES AND BENEFITS

- Dual motor design provides extremely fast rundown speed
- Improved torque to weight ratio
- Full swivel gearcase facilitates reaction bar positioning for ease of use and operator comfort
- Handle exhaust with low sound level
- Uses the same durable and reliable gearbox from our DC line of high torque tools
- Modular design allows for easy maintenance
- Two-piece handle construction enables flexible handle design
- Available in reversible and non-reversible models



AAP2B Series Tools

Model	Torque		Speed (RPM)	Weight		Length		Square Dr. (IN)
	(NM)	(FT-LB)		(LB)	(KG)	(IN)	(MM)	
AAP2B76250A	250	185	660	10.5	4.8	10	255	3/4
AAP2B76450A	450	330	335	10.5	4.8	10	255	3/4
AAP2B76650A	650	480	223	10.5	4.8	10	255	3/4
AAP2B76950A	950	700	153	10.5	4.8	10	255	3/4
AAP2B771400A	1,400	1,000	110	14.6	6.6	10	255	1
AAP2B772000A	2,000	1,475	63	14.8	6.7	11.2	284	1
AAP2B773000A	3,000	2,210	52	15.0	6.8	11.6	293	1
AAP2B785100A	4,800	3,540	26.5	19.7	8.9	13.3	338	1.5

AAP2B Series Reversible Tools

Reversible Model	Torque		Speed (RPM)	Weight		Length		Square Dr. (IN)
	(NM)	(FT-LB)		(LB)	(KG)	(IN)	(MM)	
AAP2B76250AR	250	185	660	12.3	5.6	12.5	317	3/4
AAP2B76450AR	450	330	335	12.3	5.6	12.5	317	3/4
AAP2B76650AR	650	480	223	12.3	5.6	12.5	317	3/4
AAP2B76950AR	950	700	153	12.3	5.6	12.5	317	3/4
AAP2B771400AR	1,400	1,000	110	16.4	7.4	12.6	319	1
AAP2B772000AR	2,000	1,475	63	16.6	7.5	13.6	346	1
AAP2B773000AR	3,000	2,210	52	16.8	7.6	14.0	356	1
AAP2B785100AR	4,800	3,540	26.5	21.5	9.7	15.8	400	1.5

AcraDyne HT Pneumatic Tool Accessories

Polyurethane Hose for HT Tools



- Durable Polyurethane is chemical resistant and lightweight, and provides excellent recoil memory and maximum flexibility
- Available in transparent hose color (opaque also available)
- Assemblies for coiled hose include reusable swivel fitting. Straight hose available with or without fittings
- Working temperature: -104° F to 175° F
- Working pressure: 100 PSI

Single Air Hose Assemblies (Coiled)

Model	Description (O.D. x I.D. x Length)	Retracted Length	Npt Fittings
ASH-500C-15MSZ	3/4" x 1/2" x 15'	13"	1/2"
ASH-500C-25MSZ	3/4" x 1/2" x 25'	23"	1/2"

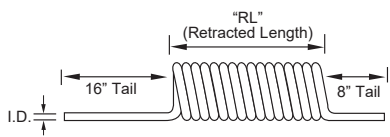

Custom length coil assemblies and special colors available in minimum order quantities. Contact an AIMCO Customer Service Associate, 1-503-254-6600, or toll free 1-800-852-1368.



Straight Air Hose (Sold Per Foot)

MODEL	DESCRIPTION
ASH-500Z	1/2" I.D.

Contact an AIMCO Customer Service Associate about full reel pricing, 1-503-254-6600, or toll free 1-800-852-1368.

Rubber Hose for HT Tools



- Designed for use in a wide range of industrial, construction, and agricultural applications
- Constructed of high grade, reinforced EPDM synthetic rubber
- Working temperature: -40° F to 190° F

Single Air Hose (Rubber)

I.D.	O.D.	Length	Working Pressure	Weight
1/2"	0.81"	10 ft	200 psi	2.0 lb
5/8"	0.97"	10 ft	200 psi	2.7 lb
3/4"	1.12"	10 ft	200 psi	3.4 lb

Custom lengths available. Contact an AIMCO Customer Service Associate for more details, 1-503-254-6600, or toll free 1-800-852-1368.

REACTION BARS

Tool includes standard, spline attachment reaction device. See page 42 for part numbers. Custom reaction devices are available; contact an AIMCO Customer Service Associate for more details, 1-503-254-6600, or toll free 1-800-852-1368.



Air Line Fittings



Plugs

Model	Description
28161	1/2" x 1/4" MPT
28162	1/2" x 3/8" MPT
28163	1/2" x 1/2" MPT
28164	1/2" x 1/2" FPT

Quick-Change Couplers

Model	Description
27768	1/2" FPT
27769	1/2" MPT

Protective Coupler

Model	Description
27771	Vinyl

Swivel Fitting

Model	Capacity
500-SZ	1/2" NPT Swivel Fitting

Ergo Arm Tool Support Systems

ERGO ARMS



Versatile Ergo Arms Absorb Torque Reaction while Perfectly Balancing Tool Weight

AIMCO's Ergo Arms reduce operator fatigue for electric and pneumatic tools. The versatile, easy-to-assemble kits include both single and parallel rails for customizing tool rigidity to the customer's preference.

The durable, lightweight construction provides minimal resistance and low inertia during high-cycle use. The adjustable height, length, and elbowed joint increases accessibility with minimal travel to the fastening application.

Tools recommended for use with this arm:

- AcraDyne 1000 and 2000 Series
- Uryu LT Series Pneumatic Screwdrivers
- Electra Electric Screwdrivers
- Inline Tools

SPECIAL FEATURES OF ERGO ARMS

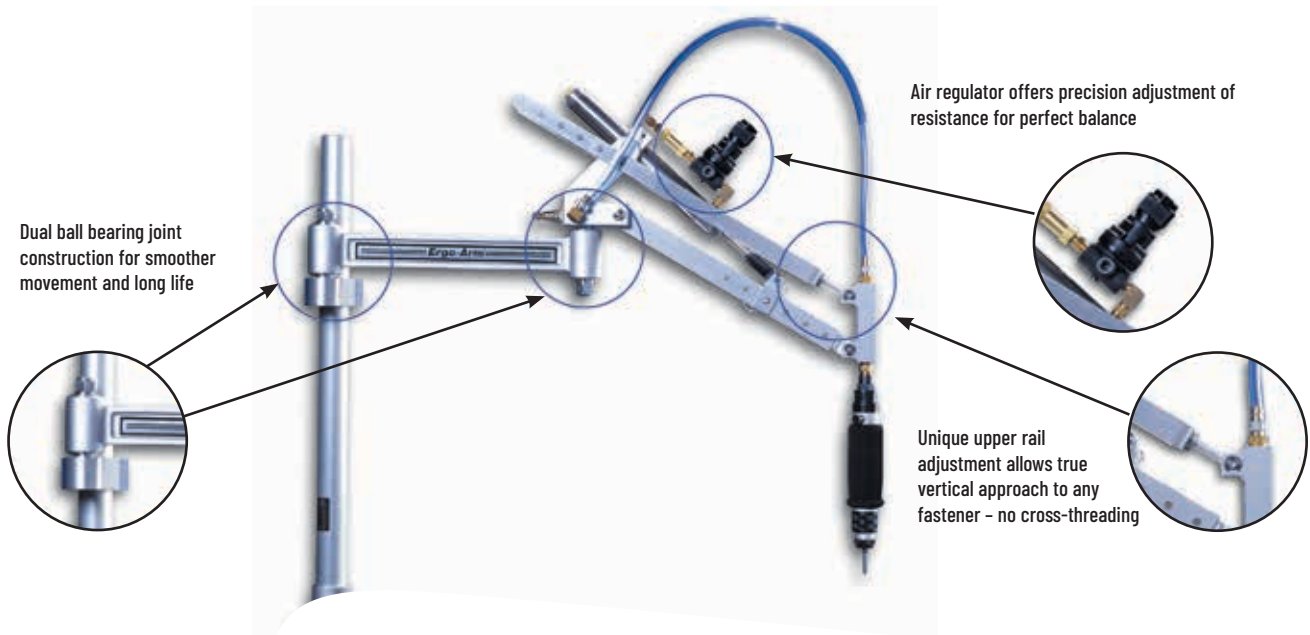

Ergo Arm Tool Support Systems

ERGO ARM FEATURES AND BENEFITS



PARALLEL ARM SERIES

AD-D1098-P, AD-D1098-PAC, AD-D1098-PACE

- Allows for freedom of movement
- Vertical adjustment eliminates cross-threading
- Fixtured tool increases repeatability
- Adjustable reach
- Available in air or oil cylinder models
- Electric tool mount standard on PACE model

SINGLE ARM SERIES

AD-D1098-S, AD-D1098-SAC

- Full tool rotation
- Allows for freedom of movement
- Adjustable reach
- Compatible with automatic screw feeder
- Available in air or oil cylinder models

AD Series Ergo Arms

Model	Arm Style	Tool Mount	Reach		Capacity		Maximum Torque*	
			IN	MM	LB	KG	IN-LB	NM
AIR CYLINDER SERIES								
AD-D1098-SAC	Single	Air manifold	4 - 33	102 - 838	0 - 15	0 - 7	110	12
AD-D1098-PAC	Parallel	Air manifold	4 - 33	102 - 838	0 - 15	0 - 7	110	12
AD-D1098-PACE	Parallel	Electric	4 - 33	102 - 838	0 - 15	0 - 7	110	12
OIL CYLINDER SERIES								
AD-D1098-S	Single	Air manifold**	4 - 33	102 - 838	0 - 15	0 - 7	110	12
AD-D1098-P	Parallel	Air manifold	4 - 33	102 - 838	0 - 15	0 - 7	110	12

* Max torque allowed may be dependent on tool clutch type and joint rate
 ** For single arm electric tool mount, order EAP-202ED-KIT

Carbon Torque Arms

ACA SERIES TELESCOPIC CARBON ARMS



Telescopic Torque Reaction Arms Provide Complete Ergonomics in the Hand-Tightening Phase

ACA Series Carbon Arms are lightweight, yet strong devices designed to absorb torque reactive forces. Highly flexible and modular, they adapt to a wide range of tools, and eliminate hazards to operators during fastening processes.

Tools recommended for use with this arm:

- Continuous Drive Electric and Pneumatic Tools
- Pulse Tools
- Screwdrivers

FEATURES AND BENEFITS

- Absorb torque reaction from continuous drive tools
- Counter balance tool weight when configured with AIMCO's wide array of tool balancers or with integrated balancer kits
- Orient tool correctly to the workpiece to improve efficiency and reduce operator effort in alignment to the fastener

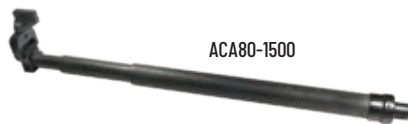

ACA80-1500



ACA-V15-1000

ACA Series Carbon Torque Arms

Model	Min. Length MM	Max. Length MM	Max Torque NM
ACA10-1000	495	1,105	10
ACA10-1500	665	1,605	10
ACA15-1000	486	1,066	15
ACA15-1500	646	1,556	15
ACA15-2000	806	2,046	15
ACA40-1000	486	1,066	40
ACA40-1500	646	1,556	40
ACA40-2000	806	2,046	40
ACA40-2500	986	2,576	40
ACA80-1500	658	1,586	80
ACA80-2000	828	2,078	80
ACA80-2500	998	2,588	80
ACA150-1500	668	1,578	150
ACA150-2000	838	1,918	150
ACA150-2500	1003	2,248	150
ACA220-1500	668	1,578	220
ACA220-2000	838	2,088	220
ACA220-2500	1,003	2,588	220

ACA-V Series Carbon Torque Arms

Model	Min. Length MM	Max. Length MM	Max Torque NM
ACA-V15-1000	777	1,345	15
ACA-V15-1500	937	1,835	15
ACA-V15-2000	1,097	2,325	15
ACA-V40-1000	777	1,345	40
ACA-V40-1500	937	1,835	40
ACA-V40-2000	1,097	2,325	40
ACA-V40-2500	1,277	2,855	40
ACA-V80-1500	949	1,865	80
ACA-V80-2000	1,119	2,357	80
ACA-V80-2500	1,289	2,867	80
ACA-V150-1500	960	1,957.5	150
ACA-V150-2000	1,129	2,357	150
ACA-V150-2500	1,294	2,862	150
ACA-V220-1500	960	1,957.5	220
ACA-V220-2000	1,129	2,357	220
ACA-V220-2500	1,294	2,867	220

Carbon Torque Arms

ACA-P2 CARBON SMART ARM



ACA-P2 Series Carbon Torque Smart Arm w/X,Y Axis Encoders

(Requires ACA-POSIX System or AcraDyne's Gen IV Smart Arm System)

Model	Min. Length MM	Max. Length MM	Max Torque NM
ACA-P215-1000	647	1,227	15
ACA-P215-1500	803	1,713	15
ACA-P215-2000	977	2,227	15
ACA-P240-1000	647	1,227	40
ACA-P240-1500	803	1,713	40
ACA-P240-2000	977	2,227	40
ACA-P240-2500	1,157	2,737	40
ACA-P280-1500	830	1,757	80
ACA-P280-2000	1,000	2,249	80
ACA-P280-2500	1,169	2,760	80
ACA-P2150-1500	839	1,749	150
ACA-P2150-2000	1,009	2,087	150
ACA-P2150-2500	1,174	2,419	150
ACA-P2220-1500	839	1,749	220
ACA-P2220-2000	1,009	2,259	220
ACA-P2220-2500	1,174	2,760	220



Balancer Kits for ACA-P2 Series Carbon Torque Smart Arms

Model	Min. Capacity KG	Max. Capacity KG
ACA-P2BK-4	2	4
ACA-P2BK-6	4	6
ACA-P2BK-8	6	8
ACA-P2BK-10	8	10
ACA-P2BK-14	10	14

Encoder Options for ACA-P2 Smart Arm

AcraDyne Gen IV Smart Arm System With Process Visualization

AcraDyne's Gen IV controller with smart arm capability and process visualization provides an advanced error-proofing solution to ensure the quality of your fastening operation. The capability is integrated into the Gen IV controller – no need for an external PC or software. See page 13 for more details.



FEATURES AND BENEFITS

- Easy to follow visual guidance directly on the Gen IV controller graphical screen
- Easy to program and set up
- Low cost solution vs. competitive offerings
- Modular – can be added at any time to an existing AcraDyne system using the Gen IV controller

ACA-POSIX Positioning System

The compact, self-contained ACA-Posix process visualization system guides operators through their assigned tasks. It connects to ACA-P2 series arms with integrated balancer kits.



FEATURES AND BENEFITS

- Intuitive and simple programming on 7" color LCD touch-screen display
- Store up to 500 unique assembly sequences
- Communicates directly with Power Tool controllers over digital I/O
- Store and display product images or CAD drawings. Images/drawings are displayed with targeting sequences to direct operators easily through their task
- Output for synchronizing with line controls

Carbon Torque Arms



TOOL HOLDERS FOR TELESCOPING CARBON ARMS

Tool Holders For AcraDyne Tools

Model	Description
ACAH-40PS1000	Tool holder for carbon fiber arm, AcraDyne 1000 series pistol/straight tools, 40 Nm
ACAH-80PS3-5000	Tool holder for carbon fiber arm, AcraDyne 3000/5000 series pistol/straight tools, 80 Nm
ACAH-150PS3-5000	Tool holder for carbon fiber arm, AcraDyne 3000/5000 series pistol/straight tools, 150 Nm



General Tool Holders

Model	Description	Min. Tool Grip MM	Max. Tool Grip MM	
For Telescoping Arms				
Base Tool Holders				
	ACAH-15	Base tool holder 4 screws	27	45
	ACAH-40-80	Base tool holder 4 screws	30	60
	ACAH-150-220	Base tool holder 4 screws	40	70
Multi-Position Tool Holders				
	ACAH-15-MPE2745	Multi-position tool holder interface	27	45
	ACAH-150220-MPE4070	Multi position tool holder	40	70
	ACAH-4080-MPE2745	Multi-position tool holder	27	45
Swivel Tool Holders				
	ACAH-S154080	Swivel tool holder 20 to 35 mm	20	35
	ACAH-SL15150	Swivel tool holder 40 to 55 mm	40	55



Carbon Torque Tubes

ACCT & ACPTT SERIES CARBON TORQUE TUBES



ACPTT Series
Anti-Rotation Torque Tube
with articulation support



ACCT Series
Anti-Rotation Torque Tube

Carbon Torque Tubes Are Universal Arms With an Exclusive Design For Maximum Tightening Flexibility

ACCT and ACPTT series carbon torque tubes provide smooth and accurate tool travel from bearing splined shaft construction. These sturdy arms are available in torque ranges of 15 – 80 Nm. They can be used with a variety of tool holders.

Tools recommended for use with this arm:

- Continuous Drive Electric and Pneumatic Tools
- Pulse Tools



ACTT-V40-850 300

ACTT Series Carbon Torque Tubes

Model	Min. Length Mm	Max. Length MM	Max Torque NM
ACTT-V15-600 150	150	600	15
ACTT-V15-800 300	300	800	15
ACTT-V40-600 150	150	600	40
ACTT-V40-850 300	300	850	40
ACTT-V40-1500 600	600	1,500	40
ACTT-V80-900 300	300	900	80
ACTT-V80-1500 600	600	1,500	80
ACTT-V80-2100 900	900	2,100	80

FEATURES AND BENEFITS

- Universal arm with an exclusive design for maximum tightening flexibility
- Provides articulated anti-rotation support when torque reaction is parallel to arm axis

Carbon Torque Tubes

ACPTT SERIES CARBON TORQUE TUBES FOR ACSA ARTICULATING SUPPORT ARMS

ACPTT TORQUE TUBES



FEATURES AND BENEFITS

- ACPTT arm designed for use with the ACSA articulating support arm
- ACPTT carbon torque tube provides articulated anti-rotation support when torque reaction is parallel to arm axis
- The ACPTT/ACSA articulating support arm system allows torque reaction arm installation when the workplace can't accommodate suspended overhead structures

ACPTT Torque Tubes

Model	Min. Length MM	Max. Length MM	Max Torque NM
ACPTT-V15-510 150	150	600	15
ACPTT-V15-710 300	300	800	15
ACPTT-V40-510 150	150	600	40
ACPTT-V40-760 300	300	850	40
ACPTT-V40-1410 600	600	1,500	40
ACPTT-V80-810 300	300	900	80
ACPTT-V80-1410 600	600	1,500	80



ACSA ARTICULATING SUPPORT ARM



ACSA Articulating Support Arms

Model	Max Reach MM	Max Height MM	Max Torque NM
ACSA-600-1500	600	1,500	80
ACSA-800-1500	800	1,500	80
ACSA-1000-1500	1,000	1,500	80

* Support arm, torque tube, balancer, tool holder, and tool shown for concept.

Items sold separately

ACAHTT Tool Holders For ACTT & ACPTT Anti-Rotation Carbon Arms

	Model	Description	Min. Tool Grip MM	Max. Tool Grip MM
 <p>Straight</p>  <p>Angle</p>	ACAHTT-15A-3060	Angle Tool Holder, 15 Nm Arm	30	60
	ACAHTT-15S-2745	Straight Tool Holder, 15 Nm Arm	27	45
	ACAHTT-4080A-3165	Angle Tool Holder, 40/80 Nm Arms	31	65
	ACAHTT-40S-2745	Straight Tool Holder, 40/80 Nm Arms	27	45

GCI Torque Reaction Arms

GCI ARTICULATING TORQUE ARMS



Rugged Flexibility for Even the Most Complex Torque Applications

Constructed of durable aluminum, steel, or carbon fiber, GCI Torque Arms are available with multiple tool mounting options for application specifics. These highly ergonomic and user friendly arms are available in torque ranges of 150 Nm to 7,500 Nm and with reaches ranging up to 20 ft.

GCI arms can be designed as Smart Arms with two encoder options: PC-based AdaptiCS software (see page 67) and AcraDyne's Gen IV smart arm system with process visualization (see page 13). This complete Smart Arm system error-proofs even the most complex torque applications.

Tools recommended for use with this arm:

- AcraDyne 3000 - 9000 Series HT tools
- Angle (AEN 5000 series only)
- Straight (AES)
- Axial (AEJ)
- Pistol (AEP)
- Fixtured (AEF)

FEATURES AND BENEFITS

- Available in aluminum, steel, or carbon fiber
- Configurable installation: floor mount, wall mount, overhead mount, bench mount, or portable base
- Braking options: manual/automatic, discrete braking with verification, parking brakes, and electric/pneumatic actuation
- Tool holding options: fixed position, gimbal mount
- Integrated tool start/brake actuation capability: tool trigger start, remote tool start
- Smart Arm Capabilities:
 - Available with as many as six encoders to monitor all desirable tool positions relative to application
 - Two encoder options:
 - AcraDyne Gen IV Smart Arm System with Process Visualization (see page 13)
 - AdaptiCS PC-based software that runs on an integrated industrial PC or on a customer supplied PC (see page 67)



IP Series Arm



Carbon Fiber Arm



Rugged tablet PC option for Smart Arm

GCI Torque Reaction Arms

GCI Torque Reaction Arms

Model	Max. Torque	Max. Tool Weight	Max. Reach	Max. Vertical Travel	Construction
IPT Series - Torques to 375 Nm					
IPT150	150 Nm	12 lb	5 ft	30 in	Aluminum
IPT375	375 Nm	50 lb	6 ft	36 in	Steel
IP Series - Torques to 4,000 Nm					
IP4	550 Nm	30 lb	8 ft	48 in	Steel
IP5	1,000 Nm	50 lb	12 ft	60 in	Steel
IP7	3,000 Nm	100 lb	12 ft	60 in	Steel
IP8T	4,000 Nm	100 lb	12 ft	72 in	Steel
F Series - Carbon Fiber Arms					
F70	70 Nm	10 lb	3 ft	18 in	Carbon Fiber Composite
F600	600 Nm	50 lb	20 ft	72 in	Carbon Fiber Composite
F1500	1,500 Nm	50 lb	20 ft	72 in	Carbon Fiber Composite
F3000	3,000 Nm	75 lb	20 ft	72 in	Carbon Fiber Composite
F7500	7,500 Nm	75 lb	12 ft	72 in	Carbon Fiber Composite

GCI ARM OPTIONS

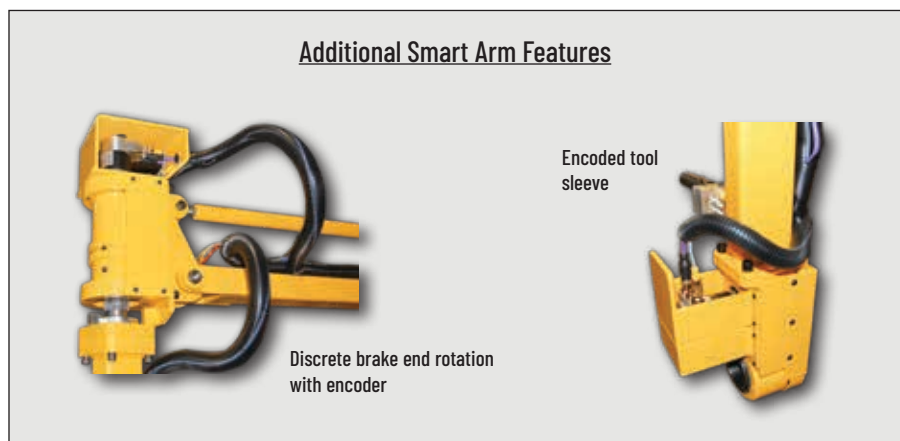
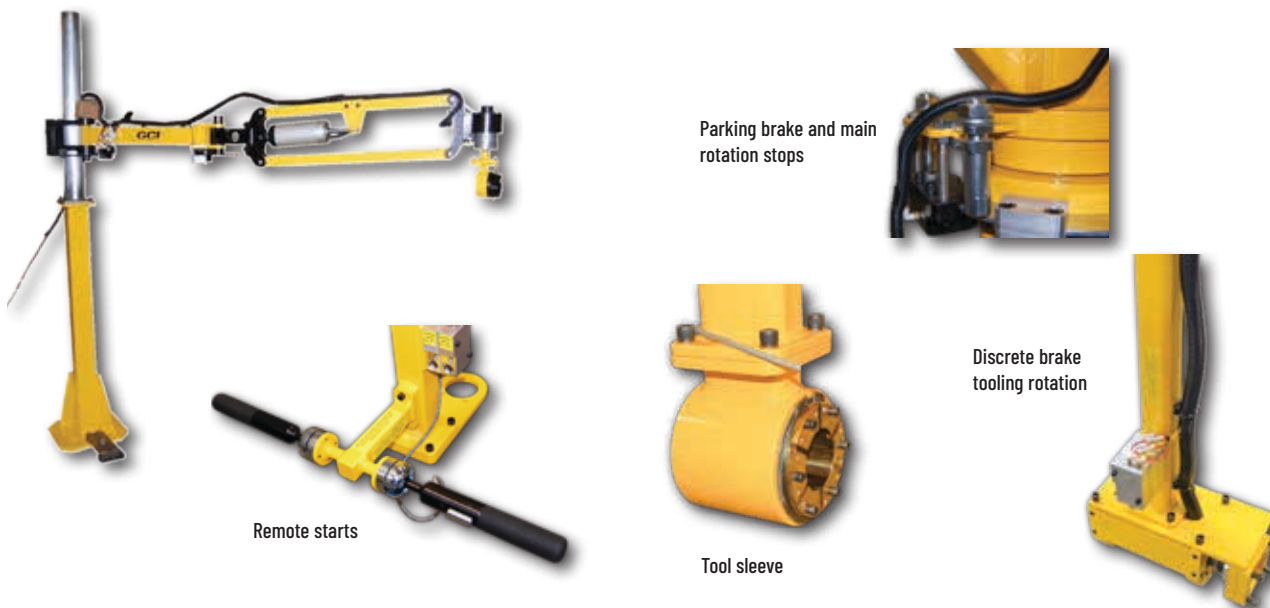

Encoder Options for GCI Smart Arms

AcraDyne Gen IV Smart Arm System with Process Visualization

AcraDyne's Gen IV controller with smart arm capability and process visualization provides an advanced error-proofing solution to ensure the quality of your fastening operation. The capability is integrated into the Gen IV controller – no need for an external PC or software. See page 13 for more details.

FEATURES AND BENEFITS

- Easy to follow visual guidance directly on the Gen IV controller graphical screen
- Easy to program and set up
- Low cost solution vs. competitive offerings
- Modular – can be added at any time to an existing AcraDyne system using the Gen IV controller

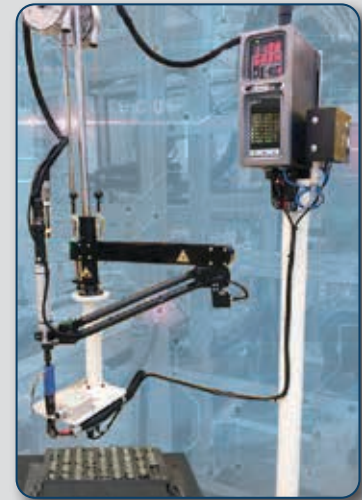

AdaptiCS Software

Intuitive, user-friendly AdaptiCS PC-based software that runs on an integrated industrial PC or on a customer supplied PC. Smart arms guide the operator in programmable torque patterns and count fasteners required for correct assembly.

FEATURES AND BENEFITS

- Batch count capabilities
- Bidirectional arm articulation tracking
- Full torque/angle results display
- Integrates into any line control (PLC, MES, etc.)
- Multiple part locate strategies (1-point, 2-point, 3-point)
- Multiple rework strategies to fit requirements
- Fully programmable dynamic display with integrated PC option
- Integrates devices such as torque controllers via open protocol, encoded GCI torque reaction arms, scanners, vision cameras, and digital IO (pass/fail)
- AdaptiCS Enterprise (optional) provides full line control, interlocks, and data collection
- Runs on Windows 7, 8, and 10



3arm Zero Gravity Arms

3arm ZERO GRAVITY ARMS



Strong and Dependable, 3arm Ergonomic Arms Provide Full Range of Motion to Complete any Task Efficiently and Safely

Designed to keep tools and devices weightless even in difficult positions and working areas, 3arms are available with more than 29 head configurations. Add in various available accessories, and the arms can be fixed in almost any position. More than 1,000 standard combinations are available, as well as customized solutions.



Tools recommended for use with this arm:

- Tools that have sufficient mass for counter balancing and where overhead suspension is not an option

FEATURES AND BENEFITS

- Eases use of larger, higher weight tools, eliminating the hazards of operators having to physically carry the loads.
- Durable closed-case design absorbs considerable force
- Eliminates tool weight, providing not only an ergonomic benefit, but also increasing productivity
- Reduces operator fatigue and the chance of injury due to strain
- Holds any tool up to 77 lbs, keeping the tool weightless, while eliminating possible damage caused by dropping the tool
- Can be base-mounted, ceiling-mounted, or wall-mounted. Easily add precision reach by applying a rail, make it mobile with a trolley, or adding vertical reach with a mounting column
- Available with tool trigger braking. Effortlessly position the tool, stop it in place, release trigger, and float it to the next job

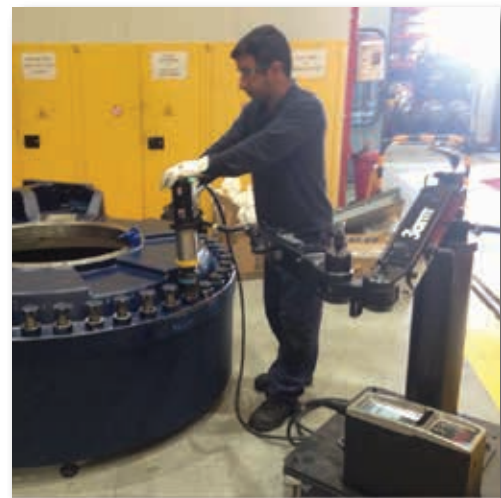

3arm Zero Gravity Arms

3arm Series 1



Light and nimble, capable of reaching even the most difficult applications.



Reach	Max Weight
Vertical: 44 in Horizontal: 42 in	22 lb

Model	Orientation	Reach (IN)		Max Weight LB
		Vert.	Horiz.	
1SNIDS	Floor Mounted	42	44	22
1AMIDS	Ceiling Mounted	42	44	22

Compatible Head Members (see page 72): B, BA, C, E, EA, F, G, K, N, T

Brake Options

L00	Not Required
-----	--------------

To build your 3arm, choose the following

Arm Model	Head Member	Brake Option

3arm Series 2



Combination radial arm and tilting arm, each capable of 360° rotation. Two arms of different lengths give you the ability to reach separate working areas.

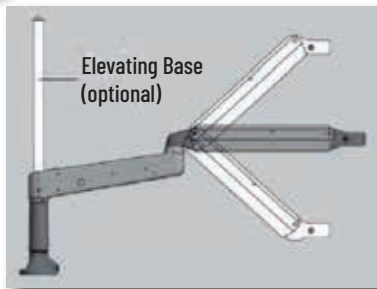

Reach	Max Weight	Max Torque
Vertical: 22 in Horizontal: 34 in	13 lb	120 Nm 88 ft-lb

Model	Orientation	Reach (IN)		Max Weight LB
		Vert.	Horiz.	
BB	Floor Mounted	22.2	33.9	13
BE	Ceiling Mounted	22.2	33.9	13
BA	Ceiling Mounted	22.2	33.9	13

Compatible Head Members (see page 72): B, BA, C, E, EA, F, G, K, N

Brake Options

L00	Not Required
-----	--------------

To build your 3arm, choose the following

Arm Model	Head Member	Brake Option



3arm Zero Gravity Arms

3arm Series 3



Reach
Vertical: 42 in
Horizontal: 68 in

Max Weight
77 lb

Max Torque
650 Nm
479 ft-lb

Versatile arm with a long reach and the ability to carry a heavy load. Features “turning and tilting” brake locking systems (pneumatic or manual), allowing the operator to immobilize the arm in a fixed position on all axes simultaneously or separately.

Model	Orientation	Reach (IN)		Max Weight LB
		Vert.	Horiz.	
Floor Mounted				
PSBS	Short Rad. + Short Tilt.	27.8	41.7	77
PSBM	Short Rad. + Long Tilt.	44.5	53.5	40
PLBS	Long Rad. + Short Tilt.	27.8	55.9	77
PLBM	Long Rad. + Long Tilt.	44.5	67.6	40
Ceiling Mounted				
PEBS	Short Rad. + Short Tilt.	27.8	41.7	77
PEBM	Short Rad. + Long Tilt.	44.5	53.5	40
ASBS	Long Rad. + Short Tilt.	27.8	55.9	77
ASBM	Long Rad. + Long Tilt.	44.5	67.6	40
Elevating Base				
ALBS	Elevating+ Short Tilt.	27.8	43.7	77
ALBM	Elevating+ Long Tilt.	44.5	55.8	40

Compatible Head Members (see page 72): All

Brake Options

L00	Not Required
L11	Manual
L22	Pneumatic
L50	Manual Locking Base
L92	Tool Trigger Activated

To build your 3arm, choose the following

Arm Model	Head Member	Brake Option

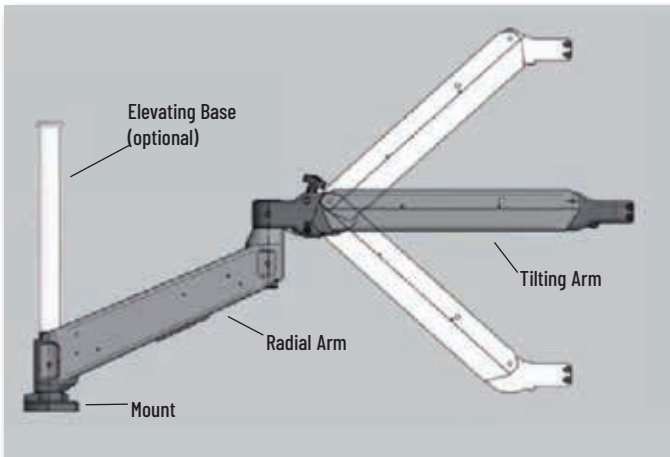

3arm Zero Gravity Arms

3arm Series 4



Reach
Vertical: 54 in
Horizontal: 58 in

Max Weight
53 lb

Max Torque
300 Nm
221 ft-lb

Model	Orientation	Reach (IN)		Max Weight
		Vert.	Horiz.	LB
DS	Floor Mounted, Short Arm	42.3	48	53
DM	Floor Mounted, Long Arm	55.5	57.5	43
ADS	Ceiling Mounted, Short Arm	42.3	48	53
ADM	Ceiling Mounted, Long Arm	55.5	57.5	43

Compatible Head Members (see page 72): All

Dual-tilting arms expand range of movement. The innovative connections between the parts of the arm allow completely free movement of rolling up, down, and sideways. Capable of reaching the most difficult positions or work with weightless precision.

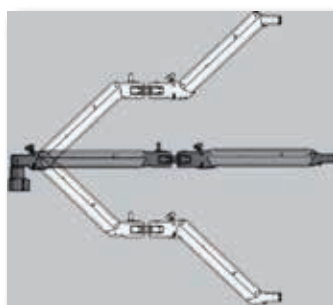

Brake Options

L00	Not Required
L11	Manual
L22	Pneumatic
L50	Manual Locking Base
L92	Tool Trigger Activated

To build your 3arm, choose the following

Arm Model	Head Member	Brake Option

3arm Series 6



Reach
Vertical: 26 in
Horizontal: 82 in

Max Weight
42 lb

Model	Description	Reach (IN)		Max Weight
		Vert.	Horiz.	LB
BPRASC	Model 800	26	68	42
BPRASM	Model 1200	26	82	26

Compatible Head Members (see page 72):
BPRASC - All
BPRASM - N,T

Extendable arm with ball linear guideways attached to a pendulum base arm, both capable of 360° rotation. This compact arm offers versatility for any type of tool. The telescopic top arm allows the user to work on hard-to-reach areas comfortably, quickly and safely. Works in a wide variety of applications.

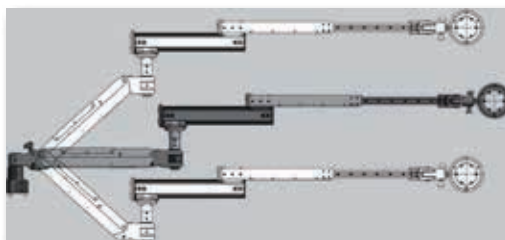

Brake Options

L00	Not Required
-----	--------------

To build your 3arm, choose the following

Arm Model	Head Member	Brake Option

3arm Zero Gravity Arms

3arm Head Members

Once you've determined the tools that will be used in you application, select a head member based on the type of application and necessary orientations.

 Vertical Flat	 Vertical with Ring	 Vertical Adjustable	 Flat Articulated	 Flat Articulated with Ring	 Articulated Adjustable	 Quick Change
 Heavy-Duty Applications	 Magnetic Articulated Drill	 Universal Strap	 Vertical Pneumatic Ball & Socket	 Constant Pressure Support	 Multiposition Articulated	 Double Articulated Flat
 Heavy-Duty Multiposition Articulated	 Swing Revolver	 Revolver Pistol	 Vertical & Horizontal	 Revolver	 Giraffe Multiposition	 Heavy-Duty Giraffe Multiposition
 Giraffe Revolver	 Multiposition Articulated Pistol	 Heavy-Duty Multiposition Articulated Pistol	 Fork			

3arm Brake Options



L11
Manual Brakes
Manually turned handle



L22
Pneumatic Brakes

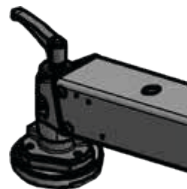

L50
Manual Locking Base
Handle at base only



L92
Tool Trigger Activated Brake
Pneumatic, activated through the tool

Support System Tool-Mounting Options

TOOL MOUNTING OPTIONS



AIMCO provides many head and mounting options to fit almost any application. Find more information in our Application Manual for Arms and Fixtures located on our website.

Contact an AIMCO Customer Service Associate for more details, 1-503-254-6600, or toll free 1-800-852-1368.



Mobile



Overhead Trolley Mount



Wall-Mount



Stationary Mount

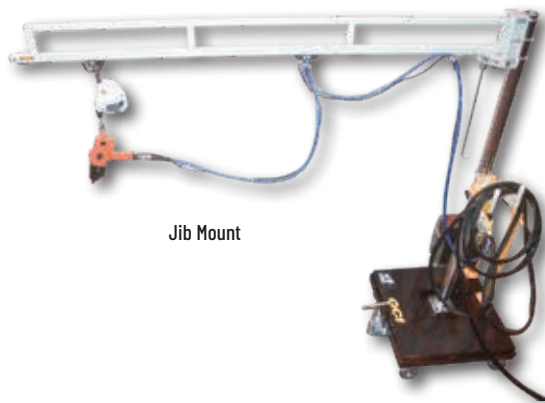

Jib Mount



Overhead Fixed Mount

Workstation Components and Assemblies

COMPONENTS

TRACK

Steel with beige polyester finish. Use for vertical and horizontal workstation support.

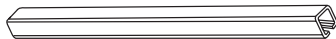

PART NUMBER	30# TRACK
AT3-3	3 ft track
AT3-4	4 ft track
AT3-6	6 ft track
AT3-9*	9 ft track

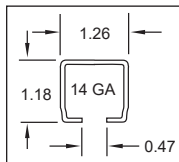

PART NUMBER	50# TRACK
AT5-3	3 ft track
AT5-4	4 ft track
AT5-6	6 ft track
AT5-9*	9 ft track
AT5-12*	12 ft track

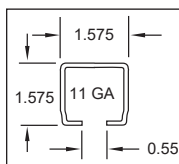

TRACK NUT (ATN-3/5)

Zinc plated steel. Use to attach accessories to track, as end stops, or to isolate rolling accessories.

- ATN-3 for 30 lb. track
- ATN-5 for 50 lb. track



END STOP (AES-3/5)

Zinc oxide finish. Use to prevent balancer trolley from "overtraveling" horizontal track.

- AES-3 for 30 lb. track
- AES-5 for 50 lb. track

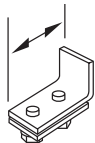

MOUNTING PLATE (AMP-5)

Black polyester finish. Use as a base to mount vertical uprights.

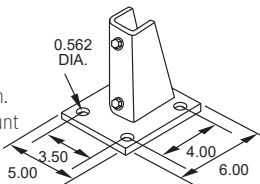

END CAP (AEP-3/5)

Black molded vinyl. Use to cap track ends for a professional finish.

- AEP-3 for 30 lb. track
- AEP-5 for 50 lb. track

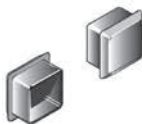

ANGLE BRACKET (AB-3/5)

Black polyester finish. Use to mount horizontal track to vertical track.

- AB-3 for 30 lb. track
- AB-5 for 50 lb. track

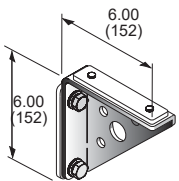

JOINT HANGER BRACKET (AJH-3/5)

Black polyester finish. Use to couple and hang end-to-end track.

- AJH-3 for 30 lb. track
- AJH-5 for 50 lb. track

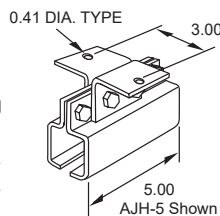

BALANCER TROLLEY (ABT-3/5)

Black polyester finish. Use as moving support for tool balancers, hose, and cable. Quality ball bearing wheels for long life and smooth tracking.

- ABT-3 for 30 lb track (1.00 dia)
- ABT-5 for 50 lb track (1.25 dia)

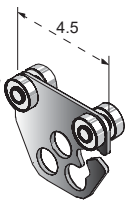

HANGER BRACKET (AHB-3/5)

Black polyester finish. Use to suspend track at right angle.

- AHB-3 for 30 lb. track
- AHB-5 for 50 lb. track

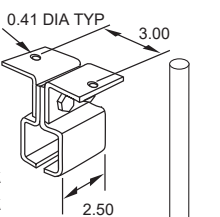

VERTICAL COLUMN (AVC-5*)

Beige polyester finish, 3" diameter x 9 ft upright steel column with welded base. Use as floor mount for extra stability with jibs or workstation components.

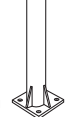

HOSE/CABLE TROLLEY

Black polyester finish. Use for moving cable or hose festoon. Supports hose cable OD .60-.94.

- AIC5-2 for 50 lb. track

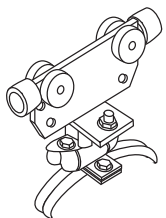

U-BOLTS (AUB-5)

Zinc plated steel. Use to secure boom bracket, or any flat metal plate, to AVC-5 (sold individually).

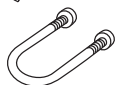

SUPPORT CLAMPS (ASC-3/5)

Black polyester finish. Use as additional support for track.

- ASC-3 for 30 lb. track
- ASC-5 for 50 lb. track

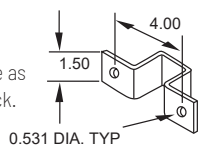

TOOL CLIP (SH-5)

Steel clip with safety latch. Use for tool attachment and as replacement clip for lightweight tool balancers. Measures 2.37" long.

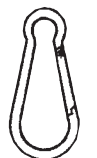

90° CONNECTOR FOR 3/8" HOSE (WSCH)

3/8" I.D. Brass. Use to provide stable transfer point from air line to tool. 90 degree connector attaches to ABT-5.

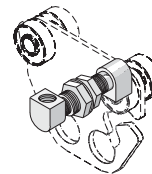

WALL- AND FLOOR- MOUNTED JIBS

3 FT. SWINGING JIB (AW3S)

3 FT FIXED JIB (AW3F)

3 FT. SWINGING JIB FOR CHANNEL MOUNT (AJS3**)

Jibs are mounted to wall or beams to create free standing workstations. End stop, end cap, and balancer trolley included. Maximum weight: 30 lb.

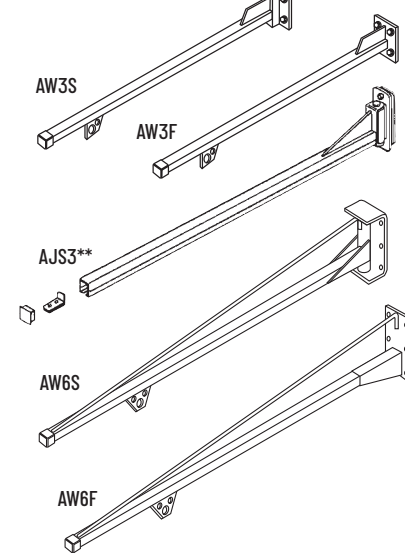

6 FT. SWINGING JIB (AW6S)

6 FT FIXED JIB (AW6F)

Jibs can be wall mounted or attached to vertical column (AVC-5) to create a freestanding workstation. End stop, end caps, and balancer trolley are included. Maximum weight: 50 lb.

All complete assemblies are beige polyester finish and include balancer trolley, end caps, and end stops. Floor mounted assemblies are not able to ship via UPS.

When choosing a workstation system, remember...

Total weight capacities should include tool balancer, hose/cable, and tool/fixture. Units need to be supported vertically and horizontally every 6 ft.

** Additional freight may apply

** AJS3 Does not include balancer trolley

Index

MODEL #	PAGE	MODEL #	PAGE	MODEL #	PAGE	MODEL #	PAGE	MODEL #	PAGE
A		ACA-P2220-2000	.61	AEN4C 1000 Series Angle Tools	.15	AT3-6	.74	20853	.47
AAP1B66400A	.55	ACA-P2220-2500	.61	AEN4C 2000 Series Angle Mid-Exit Cable Tools	.20	AT3-9	.74	21159	.47
AAP1B66600A	.55	ACA-V15-1000	.60	AEN4C 2000 Series Angle Tools	.18	AT5-3	.74	21208	.47
AAP1B66850A	.55	ACA-V15-1500	.60	AEN4F 2000 Series Angle Mid-Exit Cable Tools	.20	AT5-4	.74	21226	.47
AAP1B76950A	.55	ACA-V15-2000	.60	AEN4F 2000 Series Angle Tools	.18	AT5-6	.74	23575	.47
AAP1B771350A	.55	ACA-V40-1000	.60	AEP-3	.74	AT5-9	.74	23662	.47
AAP1B772000A	.55	ACA-V40-1500	.60	AEP3 5000 Series Pistol Tools	.25	AT5-12	.74	23730	.45
AAP1B772950A	.55	ACA-V40-2000	.60	AEP4 1000 Series Pistol Tools	.14	ATN-3	.74	24320	.45
AAP1B885100A	.55	ACA-V40-2500	.60	AEP4 1000 Series Riv-Nut Tools	.29	ATN-5	.74	24330	.45
AAP2B76250A(R)	.56	ACA-V80-1500	.60	AEP4A 2000 Series Pistol Tools	.17	AUB-5	.74	24924	.47
AAP2B76450A(R)	.56	ACA-V80-2000	.60	AEP4A 2000 Series Riv-Nut Tools	.29	AVC-5	.74	25265	.47
AAP2B76650A(R)	.56	ACA-V80-2500	.60	AEP4A 2000 Series HT Dual-Lever Tools36	.30	AW3F	.74	25274	.42
AAP2B76950A(R)	.56	ACA-V150-1500	.60	AEP4A 2000 Series HT Tools	.17	AW3S	.74	25275	.42
AAP2B771400A(R)	.56	ACA-V150-2000	.60	AEP4A 6000 Series HT Dual-Lever Tools36	.30	AW6F	.74	25276	.42
AAP2B772000A(R)	.56	ACA-V150-2500	.60	AEP4A 6000 Series HT Tools	.30	AW6S	.74	25277	.42
AAP2B773000A(R)	.56	ACA-V220-1500	.60	AEP4A 7000 Series HT Dual-Lever Tools36	.30	AXD-2000	.39	25278	.42
AAP2B785100A(R)	.56	ACA-V220-2000	.60	AEP4A 7000 Series HT Tools	.30	AXD-2000B	.39	25287	.42
AB-PBA1L	.52	ACA-V220-2500	.60	AEP4A 8000 Series HT Dual-Lever Tools36	.30			25289	.42
AB-PCOLRING	.52	ACPTT-V15-510 150	.64	AEP4A 8000 Series HT Tools	.30	B		25291	.42
AB-3	.74	ACPTT-V15-710 300	.64	AEP4(A)(R)(T)22020B(V)	.17	BA Series 3arm	.69	25350	.45
AB-3/5	.74	ACPTT-V40-510 150	.64	AEP4B 6000 Series HT Tools	.31	BB Series 3arm	.69	25491	.45
AB-5	.74	ACPTT-V40-760 300	.64	AEP4B 7000 Series HT Dual-Lever Tools36	.31	BE Series 3arm	.69	25501	.47
AB-B1825LI	.52	ACPTT-V40-1410 600	.64	AEP4B 7000 Series HT Tools	.31	BJ1005.1	.46	25518	.45
AB-B1850LI	.52	ACPTT-V80-810 300	.64	AEP4B 8000 Series HT Dual-Lever Tools36	.31	BJ1005.2	.46	25717	.47
AB-C18-4W	.52	ACPTT-V80-1410 600	.64	AEP4B 8000 Series HT Tools	.31	BJ1005.3	.46	25718	.47
AB-C18110	.52	ACSA-600-1500	.64	AEP4B 9000 Series HT Tools	.31	BJ1005.4	.46	25843	.47
AB-C18220	.52	ACSA-800-1500	.64	AEP4R 1000 Series Pistol Tools	.14	BJ1005.5	.46	26327	.42
ABN-CTA Cordless Angle Tools	.50	ACSA-1000-1500	.64	AEP4R 1000 Series Rivet Tools	.29	BJ1007.6	.42	26328	.42
ABN-MTA Cordless Angle Tools	.49	ACTT-V15-600 150	.63	AEP4R 2000 Series Pistol Tools	.17	BJ1007.7	.42	26332	.42
ABP-CTA Cordless Pistol Tools	.50	ACTT-V15-800 300	.63	AEP4R 2000 Series Rivet Tools	.29	BJ1007.8	.42	26336	.42
ABP-CTA Ultra Torque Cordless Pistol Tools	.51	ACTT-V40-600 150	.63	AEP4T 1000 Series Pistol Push-To-Start Tools	.14	BPRASC Series 3arm	.71	26337	.42
ABP-MTA Cordless Pistol Tools	.49	ACTT-V40-850 300	.63	AEP4T 1000 Series Pistol Tools	.14	BPRASM Series 3arm	.71	26364	.45
ABS-CTA Cordless Straight Tools	.50	ACTT-V40-1500 600	.63	AEP4T 2000 Series Pistol Tools	.17			26394	.47
ABS-MTA Series Cordless Straight Tools	.49	ACTT-V80-900 300	.63	AEP4T 2000 Series Rivet Tools	.29			26443	.47
ABT-3	.74	ACTT-V80-1500 600	.63	AEP4W 9X Series HTXD Tools	.38	CC-6000-F	.42	26477	.42
ABT-5	.74	AD-D1098-P	.59	AEP4W 9Y Series HTXD Tools	.38	CC-6000-FIP	.42	26478	.42
ABT-CTA Cordless Tubenut Tools	.50	AD-D1098-PAC	.59	AEP4W 8000 Series HT Tools	.31	CC-7000-F	.42	26479	.42
ACA10-1000	.60	AD-D1098-PACE	.59	AEP4W 9000 Series HTXD Tools	.38	CC-7000-FIP	.42	26568	.47
ACA10-1500	.60	AD-D1098-S	.59	AEP-5	.74	CC-8000-F	.42	26570	.47
ACA15-1000	.60	AD-D1098-SAC	.59	AEP 2000 Series Discontinuous Drive Tools	.22	CC-8000-FIP	.42	26630	.42
ACA15-1500	.60	ADM Series 3arm	.71	AES-3	.74			26800	.42
ACA15-2000	.60	ADS Series 3arm	.71	AES3 3000 Series Inline Tools	.24			26810	.42
ACA40-1000	.60	AED4A 6000 Series HT Tools	.30	AES3 5000 Series Inline Tools	.26			26815	.42
ACA40-1500	.60	AED4A 7000 Series HT Tools	.30	AES4 1000 Series Inline Tools	.15			26820	.42
ACA40-2000	.60	AED4A 8000 Series HT Tools	.30	AES4A 1000 Series Inline Mid-Exit Cable Tools	.20			26830	.42
ACA40-2500	.60	AED4B 6000 Series HT Tools	.31	AES4A 2000 Series Inline Tools	.18			26840	.42
ACA80-1500	.60	AED4B 7000 Series HT Dual-Lever Tools	.36	AES4A 2000 Series HT Dual-Lever Tools36	.30	F70	.66	26885	.42
ACA80-2000	.60	AED4W 8000 Series HT Tools	.31	AES4A 6000 Series HT Dual-Lever Tools36	.30	F600	.66	26890	.42
ACA80-2500	.60	AED4W 8000 Series HT Tools	.31	AES4A 6000 Series HT Tools	.30	F1500	.66	27045	.42
ACA150-1500	.60	AEF3 5000 Series Fixture Tools	.27	AES4A 7000 Series HT Dual-Lever Tools36	.30	F3000	.66	27110	.45
ACA150-2000	.60	AEF4A 1000 Series Fixture Tools	.16	AES4A 7000 Series HT Tools	.30	F7500	.66	27115	.45
ACA150-2500	.60	AEF4A 6000 Series HT Dual-Lever Tools	.36	AES4A 8000 Series HT Tools	.30			27122	.45
ACA220-1500	.60	AEF4A 6000 Series HT Tools	.30	AES4B 6000 Series HT Dual-Lever Tools	.36	G		27200	.42
ACA220-2000	.60	AEF4A 7000 Series HT Dual-Lever Tools	.36	AES4B 7000 Series HT Dual-Lever Tools	.36	Gen IV ACE Controller	.4	27255	.42
ACA220-2500	.60	AEF4A 7000 Series HT Tools	.30	AES-5	.74	Gen IV Smart Arm System with Process Visualization	.12	27348	.45
ACAH-15	.62	AEF4A 7000 Series HT Tools	.30	AET4A 1000 Series Tubenut Tools	.16			27594	.47
ACAH-15-MPE2745	.62	AEF4A 8000 Series HT Dual-Lever Tools36	.36	AET4A 2000 Series Tubenut Tools	.19			27768	.57
ACAH-40-80	.62	AEF4A 8000 Series HT Tools	.30	AEX4A 1000 Series Fixture Tools	.16	I		27769	.57
ACAH-40PS1000	.62	AEF4A 9000 Series HTXD Tools	.38	AFRL-4	.55	iAC4E Series Gen IV Controller	.8	27791	.47
ACAH-80PS3-5000	.62	AEF4A 9000 Series HTXD Tools	.38	AFRL-4HTA	.55	iB4E Series Gen IV Controller	.9	27816	.47
ACAH-150-220	.62	AEF4B 6000 Series HT Dual-Lever Tools36	.36	AHB-3	.74	iB4E-Z Series Gen IV Controller	.9	28050	.41
ACAH-150PS3-5000	.62	AEF4B 7000 Series HT Dual-Lever Tools36	.36	AHB-5	.74	iC4E Series Gen IV Controller	.8	28161	.57
ACAH-4080-MPE2745	.62	AEF4B 8000 Series HT Dual-Lever Tools36	.36	AIC5-2	.74	iEC4WF	.40	28162	.57
ACAH-150220-MPE4070	.62	AEF4C 1000 Series Fixture Tools	.16	AJH-3	.74	IP4	.66	28163	.57
ACAH-S154080	.62	AEFJA 8000 Series HT Dual-Lever Tools	.36	AJH-5	.74	IP5	.66	28164	.57
ACAH-SL15150	.62	AEH3 3000 Series Hold & Drive Tools	.24	AJ3	.74	IP7	.66	28178	.55
ACAHTT-15A-3060	.64	AEH3 5000 Series Hold & Drive Tools	.28	ALBM Series 3arm	.70	IP8T	.66	28292	.45
ACAHTT-15S-2745	.64	AEH4F 2000 Series Hold & Drive Tools	.19	ALBS Series 3arm	.70	iPC4E Series Gen IV Controller	.9	28475	.47
ACAHTT-40S-2745	.64	AEJ4A 6000 Series HT Tools	.30	AMP-5	.74	IPT150	.66	28480	.41
ACAHTT-4080A-3165	.64	AEJ4A 7000 Series HT Tools	.30	AMPST-2-I	.46	IPT375	.66	28489	.45
ACA-P2BK-4	.61	AEJ4A 8000 Series HT Tools	.30	AMPST-2-U	.46			28514	.42
ACA-P2BK-6	.61	AEJ4B 6000 Series HT Tools	.31	AMPST-4-I	.46	PEBM Series 3arm	.70	28549	.47
ACA-P2BK-8	.61	AEJ4B 7000 Series HT Tools	.31	AMPST-4-U	.46	PEBS Series 3arm	.70	28622	.42
ACA-P2BK-10	.61	AEJ4B 8000 Series HT Dual-Lever Tools	.36	AMPST-6-I	.46	PLBM Series 3arm	.70	28796	.57
ACA-P2BK-14	.61	AEJ4B 8000 Series HT Tools	.31	AMPST-6-U	.46	PLBS Series 3arm	.70	28843	.27
ACA-P215-1000	.61	AEJ4U 9X Series HTXD Tools	.38	AMPST-6S-I	.46	PSBM Series 3arm	.70	28859	.46
ACA-P215-1500	.61	AEJ4U 9Y Series HTXD Tools	.38	AMPST-6S-U	.46			30300	.42
ACA-P215-2000	.61	AEJ4W 9X Series HTXD Tools	.38	AMPST-8-I	.46	S		30303	.42
ACA-P240-1000	.61	AEJ4W 9Y Series HTXD Tools	.38	AMPST-8-IL	.46	SH-5	.74	30306	.42
ACA-P240-1500	.61	AEJ4W 8000 Series HT Tools	.31	AMPST-8-U	.46			30340	.47
ACA-P240-2000	.61	AEJ4W 9000 Series HTXD Tools	.38	ASBM Series 3arm	.70			30351	.47
ACA-P280-1500	.61	AEL4A 1000 Series Inline Push-To-Start Tools	.15	ASBS Series 3arm	.70	W		30355	.45
ACA-P280-2000	.61	AEN3 3000 Series Angle Tools	.23	ASC-3	.74	WSCH	.74	30850	.46
ACA-P280-2500	.61	AEN3 5000 Series Angle Tools	.26	ASC-5	.74			31273	.42
ACA-P2150-1500	.61	AEN3 5000 Series HT Angle Tools	.32	ASH-500C-15MSZ	.57	Numbers		500-52	.57
ACA-P2150-2000	.61	AEN4B 7000 Series HT Angle Tools	.34	ASH-500C-25MSZ	.57	1AM1DS Series 3arm	.69		
ACA-P2220-1500	.61			ASH-500Z	.57	1SN1DS Series 3arm	.69		
				AT3-3	.74	20322	.47		
				AT3-4	.74	20400	.46		

havasis

ÇÖZÜMÜN İLK ADI

Mersinli 2823/1 No: 2/130 Konak / İzmir

ONLINE ALIŞVERİŞ

pahaliyaalma.com

KURUMSAL İLETİŞİM

havasis.com.tr



Sipariş & Danışma Hattı

0549 449 3535

Bursa Bölge
0530 060 1029

Ankara Bölge
0553 251 5537

İstanbul Bölge
0532 440 2191



Teklif & Ürün Bilgi
hemendene@havasis.com.tr

Kalibrasyon & Bakım Onarım Merkezi
servisdestek@kalibo.com.tr